

NOTES:

A. GENERAL:

1. COMPLIANCY TO THIS DOCUMENT:

- a) USCAR COMPLIANCE MAY BE CLAIMED BY MEETING THE REQUIREMENTS IN THIS SPECIFICATION WITH THE DEVIATION IDENTIFIED AND MAY BE REFERENCED IN OTHER DOCUMENTS (DRAWINGS, DVP&R, ETC.) AS "CONFORMS TO EWCAP-001 REV. X.X"
- b) PRODUCTS DESIGNED AFTER THE DATE OF RELEASE OF THIS DOCUMENT SHALL BE COMPLIANT TO THE CURRENT REVISION OF THIS DOCUMENT.
- c) PRODUCTS THAT HAVE MET PREVIOUS REVISION(S) OF THIS DOCUMENT SPECIFICATION SHALL STILL BE CONSIDERED "USCAR COMPLIANT" TO THOSE REVISIONS AND DO NOT NEED TO BE RE-VALIDATED.

2. DEVIATIONS TO THIS DOCUMENT ARE ALLOWABLE UNDER THE FOLLOWING CONDITIONS:

- a) ALL DEVIATIONS SHOULD SHOW EQUAL OR BETTER PERFORMANCE (ELECTRICAL/MECHANICAL) AS REQUIRED BY VALIDATION SPECIFICATION.
- b) EXCEPTIONS ARE CLEARLY IDENTIFIED ON THE COMPONENT DOCUMENT.
- c) ALL DEVIATIONS ARE APPROVED BY PERSON WHO HAS INTERFACE RESPONSIBILITY.
- d) ALL RECORDS OF DEVIATION APPROVALS BE INCLUDED WITH CHANGE NOTICE DOCUMENTATION.

3. OBJECTIVE(S) OF THIS DOCUMENT:

THE SPECIFICATION CONTAINED IS INTENDED FOR APPLICATIONS:

- a) VALIDATED TO:
  - 1. SAE/USCAR-2
  - 2. FIELD CORRELATED LIFE TEST, SAE/USCAR-20
  - 3. RESTRICTED AND REPORTABLE CHEMICALS AS DEFINED IN IMDS.
- b) WHICH PROVIDE MINIMUM CURRENT RATING AS DEFINED BY THE EWCAP "RECOMMENDED PIN SIZES AND CURRENT CAPACITY" GUIDELINE.

B. DESIGN:

1. DESIGN - GEOMETRY:

- a) THE BLADE CONFIGURATIONS SHOWN IN THIS DRAWING REPRESENT HEADER BLADES ONLY
- b) THIS IS A 100% CAD GENERATED PART. THE RELEASED DRAWING IS THE MASTER FOR DIMENSIONAL OR ANY INFORMATION NOT SHOWN ON THIS DRAWING. ANALYZE THE CAD MODEL.
- c) UNLESS OTHERWISE SPECIFIED, TOLERANCES ARE AS FOLLOWS:
  - 1. LINEAR:
    - 00 TO 20 +/- 0.10
  - 2. ANGULAR:
    - 00 TO 5 +/- 1
    - >5 +/- 3
- d) PARTS MUST BE FREE FROM IMPERFECTIONS THAT AFFECT FIT AND FUNCTION.

2. MATERIALS FOR INTERFACE:

NOTE: MATERIAL CONDUCTIVITY MUST BE NOTED ON THE COMPONENT DRAWING. USE OF MATERIAL OTHER THAN SPECIFIED REQUIRES OEM APPROVAL.

- a) 0.50MM, 0.64MM, 1.2MM & 1.5MM BLADES:
  - 1. BASE MATERIAL: COPPER ALLOY; CONDUCTIVITY  $\geq$  28% IACS AT 20°C; TENSILE STRENGTH  $\geq$  410N/mm<sup>2</sup>
  - 2. PLATING TYPE: AS NOTED

- b) 2.8MM, 6.30MM BLADES:
  - 1. BASE MATERIAL: COPPER ALLOY; CONDUCTIVITY  $\geq$  40% IACS AT 20°C; TENSILE STRENGTH  $\geq$  475N/mm<sup>2</sup>
  - 2. PLATING TYPE: AS NOTED

- c) 9.5MM BLADES:
  - 1. BASE MATERIAL: COPPER ALLOY WITH CONDUCTIVITY 60% IACS MIN. AT 20°C; TENSILE STRENGTH  $\geq$  280 N/mm<sup>2</sup>

3. PLATING:

- a) AREAS CALLED OUT AS PLATED MUST BE PLATED PER THE SPECIFICATIONS CONTAINED IN THE PLATING CHART. ALL QUANTITATIVE AND QUALITATIVE PLATING MEASUREMENTS ARE THEN TAKEN IN THIS AREA.
- b) ZN-BEARING ALLOYS  $\geq$  5% (SUCH AS CA260) REQUIRE A BARRIER PLATING BETWEEN THE BASE MATERIAL AND TOP COAT.
- c) RECOMMEND A BARRIER PLATING BETWEEN SUBSTRATE AND Sn TO HELP MITIGATE WHISKER GROWTH.
- d) SILVER PLATING ON TERMINALS MUST STOP A MINIMUM OF 1MM BEFORE THE HEADER FLOOR.

4. DESIGN - MANUFACTURING:

- a) ANY PROCESS LUBRICANT REMAINING ON THE TERMINAL MUST NOT VARNISH OR DEGRADE ITS ELECTRICAL PERFORMANCE UP TO A MAXIMUM CLASS AMBIENT TEMPERATURE PER SAE USCAR-2 FOR 1008 HOURS. PROCESS LUBRICANTS SHOULD BE APPROVED BY PERSON WHO HAS INTERFACE RESPONSIBILITY. <PARA >b) WHEN CHOOSING A PLATING THICKNESS OR TYPE THE SUPPLIER SHOULD KEEP IN MIND THE EFFECT THE PLATING WILL HAVE ON THE MATING HARNESS CONNECTOR. CONSULT USCAR-2 & USCAR-25 FOR CONNECTOR INSERTION EFFORTS.

THE TABLE BELOW SHOWS TYPICAL ELECTRICAL CURRENT CAPACITY AS A REFERENCE ONLY. WORK WITH YOUR OEM CUSTOMER TO DETERMINE THE APPLICABLE TERMINAL SPECIFIC VALUE

Pin / Blade Size	Current Capacity	Typ. Max. Wire Size
0.5mm	3	0.35 mm <sup>2</sup>
0.64mm	8	0.75 mm <sup>2</sup>
1.2mm	13	1.0 mm <sup>2</sup>
1.5mm	15	1.0 mm <sup>2</sup>
2.8mm	23	3.0 mm <sup>2</sup>
6.3mm	40	4.0 mm <sup>2</sup>
9.5mm	60	10.0 mm <sup>2</sup>
14.5mm	250	50.0 mm <sup>2</sup>

NOTICE:  
This drawing, or portions of it are controlled by the Electrical Wiring Components Application Partnership(EWCAP) a subgroup of the United States Council for Automotive Research LLC (USCAR LLC).

USCAR is an LLC consisting of members from FCA US LLC, Ford Motor Company and GM Corporation.

Any change to a EWCAP controlled portion of this drawing, including a revision record change must be approved, in writing, by the responsible EWCAP representative from each USCAR member company. Each EWCAP representative authorized to sign for his or her member company is responsible for obtaining all necessary approvals within that company prior to signing for the approval of the change.

EWCAP expressly prohibits any party from changing either any EWCAP controlled portion of this drawing or any associated tooling before receiving approval, signed by the authorized representatives, of the USCAR member companies. Reference to the signed change notice must be entered in the drawing control column.

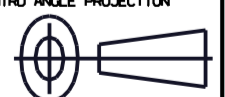
178	Z1 Z2	ADDED 14.5 BLADE ADDED DIM 2X 1.96 ± 0.20	20250226	SR	CD
169	Y1 Y2	ADDED NOTE FOR 050-T-001 REVISED NOTE FOR 064-T001, & 150-T001	20210413	SR	DP
165	X1 X2	ADDED NOTE REMOVED BLADE WIDTHS FOR IN-LINE	200402	SR	DP
158	W4 W3 W2 W1	DELETED ELECTRO TIN SILVER UPDATED PLATING NOTE FOR NICKEL UPDATED PLATING NOTE FOR GOLD UPDATED PLATING NOTE FOR SILVER REDRAWN AFTER REVISION U	190813	SR	DP
149	U4 U3 U2 U1	REMOVED CONDUCTIVITY NOTE ADDED NOTE ADDED TENSILE STRENGTH RELOCATED NOTICE	180119 180119 180119 180118	RCB RCB RCB RCB	RCB RCB RCB RCB
137	T	CORRECT DATUM A, ADD USCAR-2 REF.	161206	RCB	RCB
134	S1 S	REVISED BLADE WIDTH NOTE REDRAWN FOR CLARITY	161004	RCB	RCB
122	R	WAS 1.00 ±0.10	160414	RCB	RCB
119	P	ADDED MISSING NOTES FOR 064	160317	RCB	RCB
117	N	WAS 4X 0.50 +/- 0.03 X 45	160209	RCB	RCB
114	M4 M3 M2 M1	ADDED NOTE 3D RELATED TO SILVER REMOVED SAME AS & ADDED DIMS. WAS (120-001) ADDED (2XR 0.856) REDRAWN AFTER REVISION L	160114	DAP	RCB
109	L2 L1	ADDED MIN PLATING DISTANCE T050 REVISED 120-T001 DIMENSION SCHEME	150722	CLS	SAF
106	K	REMOVED NOTE 3D	150113	SAF	SE
100	J3 J2 J1	REMOVED NOTE 5 REVISED CURRENT CAPACITY NOTES AND CHART REVISED PLATING CHART	140414	SAF	SE
096	H5 H4 H3 H2 H1	ADDED NOTE 5 ADDED 0.50MM TO NOTES ADDED TABLE AND NOTES PREFERRED WAS OPTIONAL OPTIONAL WAS PREFERRED	120817	SAF	SE
085	G	ADDED 050-T TERMINAL BLADE	101018	DCS	SAF
072	F8 F7 F6 F5 F4 F3 F2 F1	ADDED CONTACT SURFACE ORIENTATION DIAGRAM 0.30/0.10 WAS .40/.20 (3) PLACES ADDED 950-T001 TERMINAL BLADE REVISED NOTES REVISED PLATING CHART ADDED 120-T001 TERMINAL BLADE ADDED END VIEW (2) PLACES ADDED SHEET 2 & RELOCATED VIEWS	080717	DCS	SAF
060 REV 5	E7 E6 E5 E4 E3 E2 E1	REVISED NOTES REMOVED NOTES (4) PLACES ADDED VIEW 0.64/0.61 WAS 0.64 +/-0.03 ADDED "WIDTH" & "THICKNESS" NOTES MADE THE BLADE WIDTH FOR IN-LINE CONNECTORS REFERENCE (3) PLACES MODIFIED PLATING CHART	060427	SAF	RLH
048-1	D2 D1	ADDED NOTES TO CLARIFY THE LOCATION OF THE REQUIRED PLATING (4) PLACES MODIFIED ELECTRICAL CONDUCTIVITY NOTE	041124	SAF	RLH
040	C	MODIFIED PLATING CHART AND NOTES	040519	SAF	CLS
033	B5 B4  B3 B2 B1	DEFAULT TOLERANCE 0.13 WAS 0.10 "NO BURRS" WAS "BOTH EDGES COINED ON SIDE OPPOSITE DIRECTION OF PUNCH, ENTIRE LENGTH." (3) PLACES REMOVED NOTICE NOTE REMOVED "EWCAP" FROM TITLE BLOCK MODIFIED PLATING NOTES	040108	SAF	CLS
-	A	INITIAL RELEASE	020912	SAF	SAF
CHANGE SERIAL NUMBER	LET	REVISION RECORD	DATE	DWN	CHK
TOLERANCES (UNLESS OTHERWISE SPECIFIED)			THIRD ANGLE PROJECTION		
DIMENSIONS ARE IN MILLIMETERS					

USCAR-EWCAP

SCALE NONE DRAWN BY SHEIKH RAHMAN CHECKED BY C. DILLON DATE 02/26/2025

TITLE TERMINAL BLADE DETAIL

SHEET 1 of 9 DRAWING NUMBER EWCAP-001 SIZE A2 DO NOT SCALE DRAWING COMPUTER AIDED DRAWING REVISION LEVEL Z

050-T001  
0.50 TERMINAL BLADE CONFIGURATION  
SCALE = 20:1

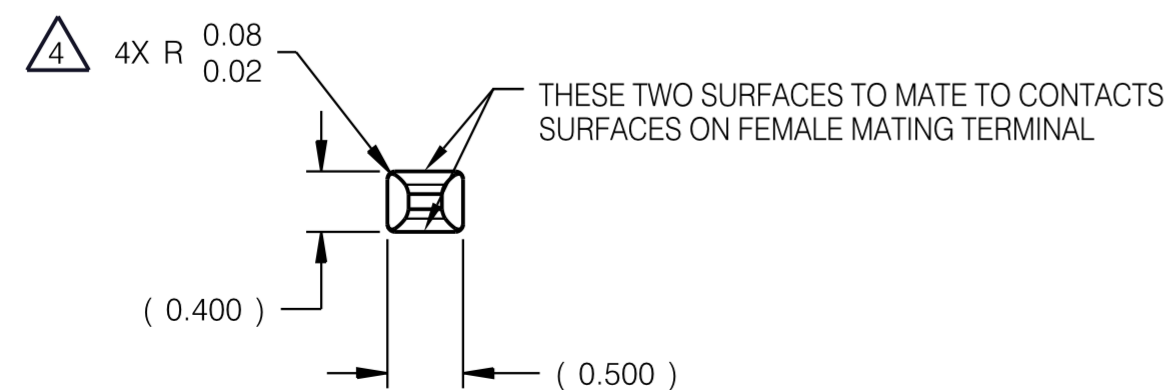
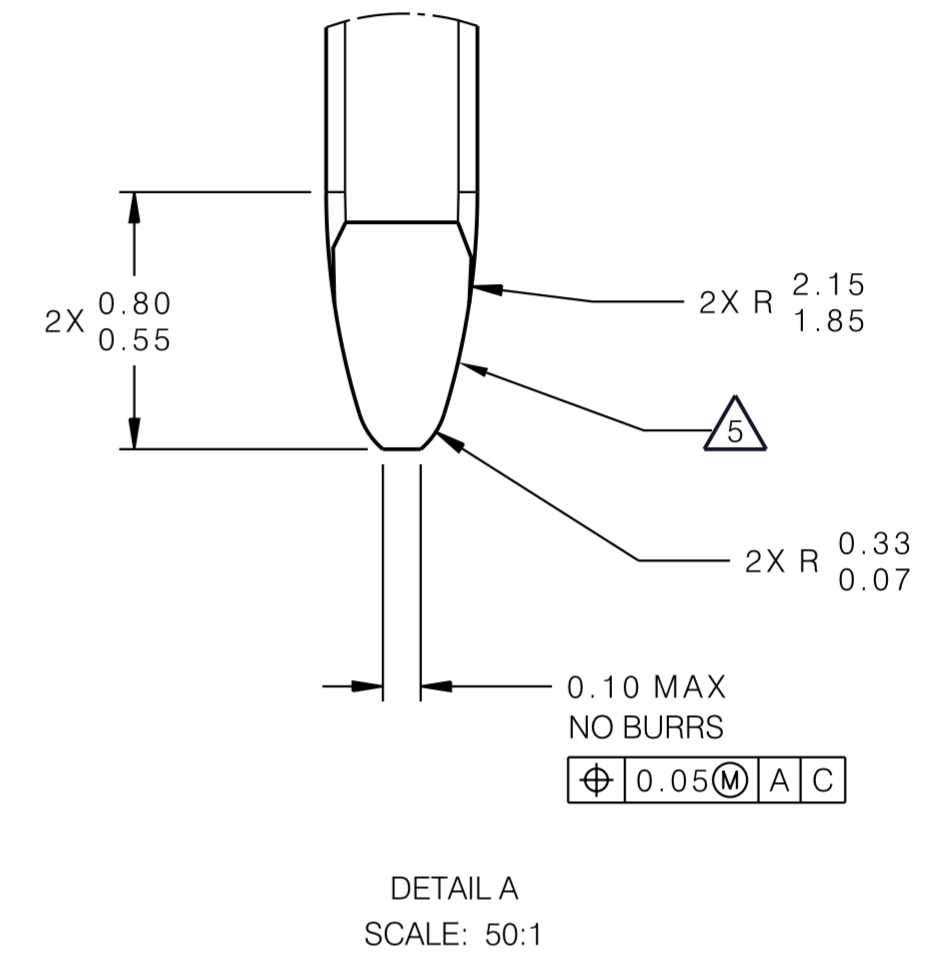
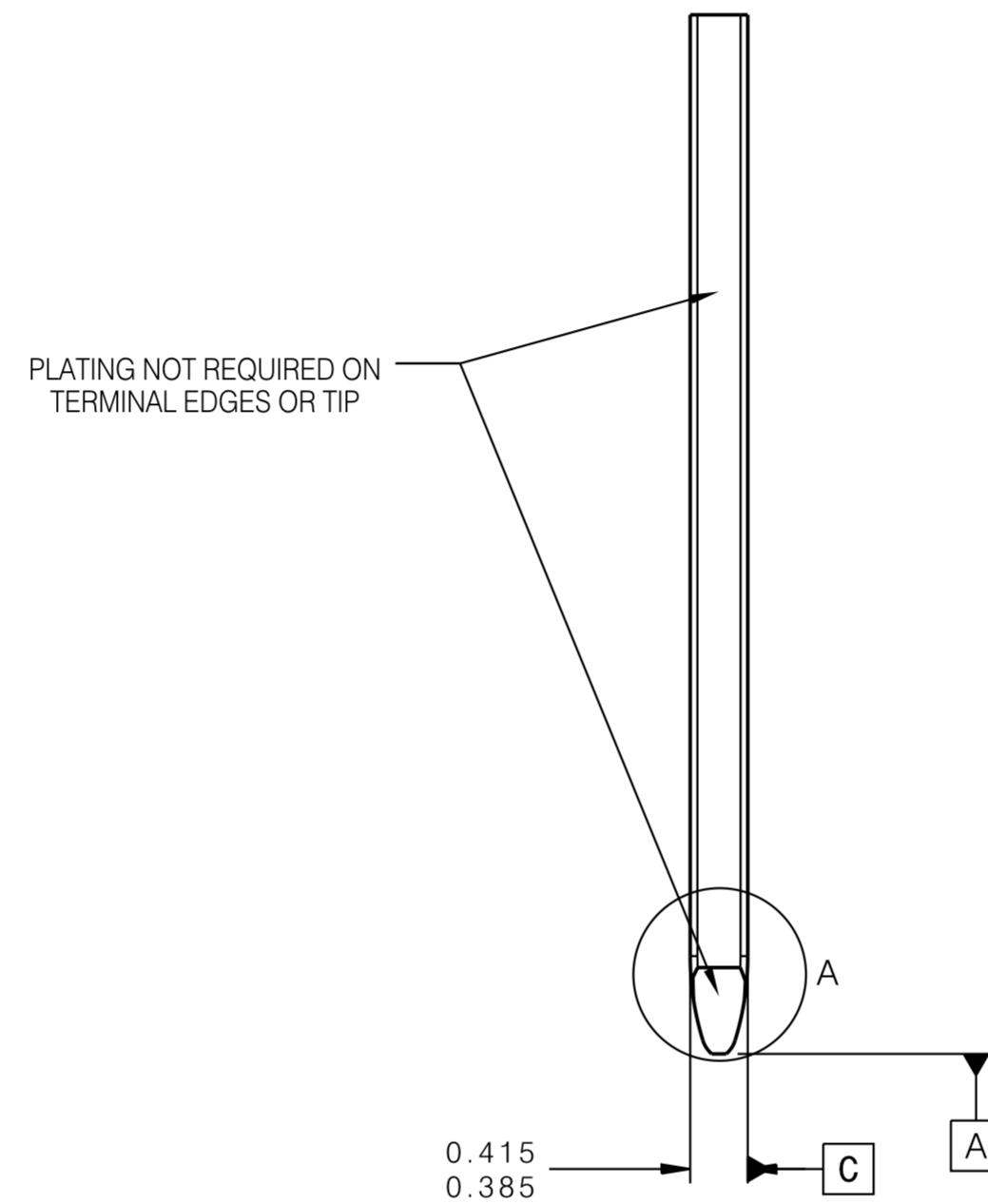
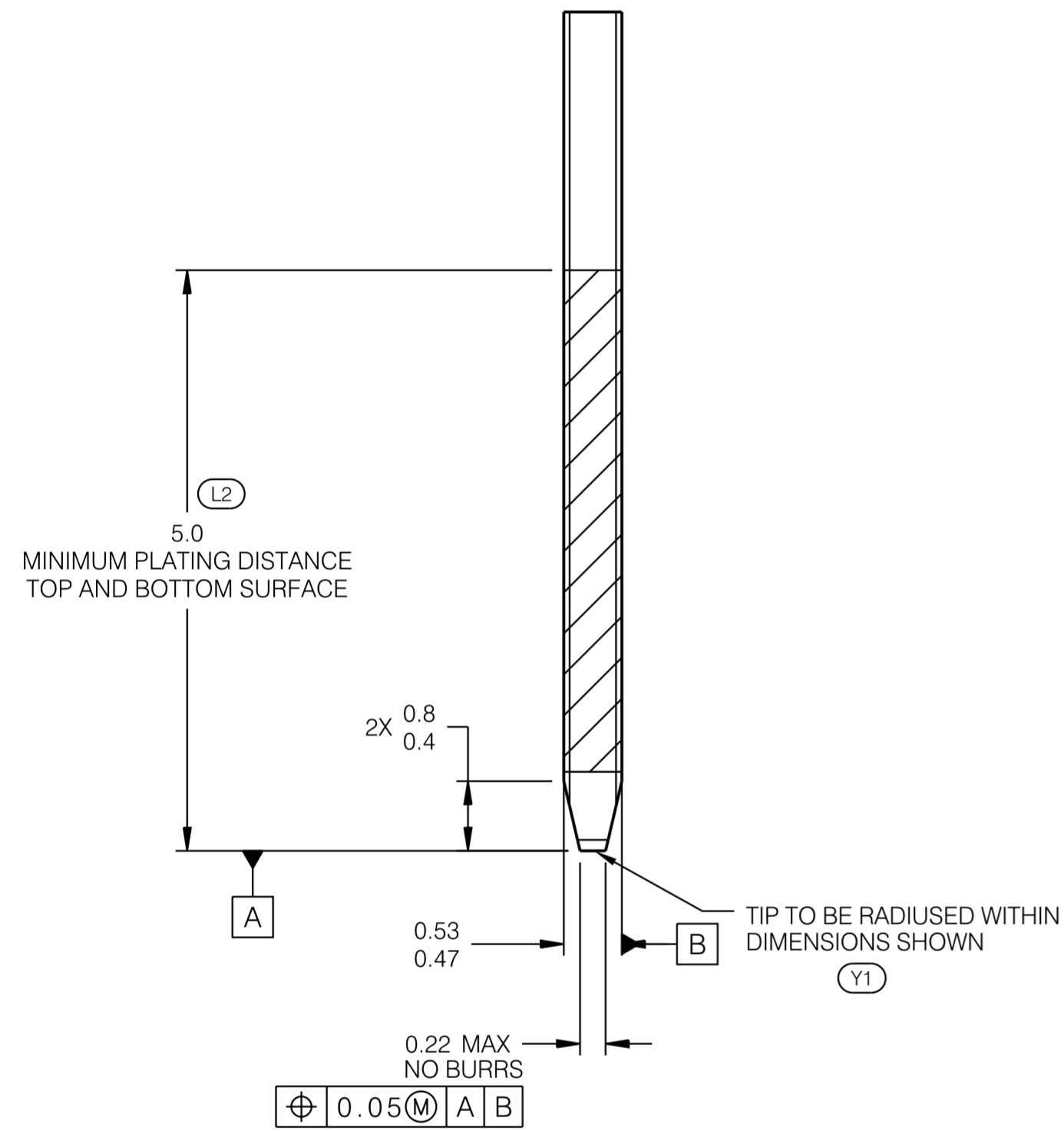

1. NO BURRS ON TIP OR PIN EDGES
  2. ALL PIN DIMENSIONS INCLUDE PLATING IF APPLICABLE
  3. BASE MATERIAL: COPPER ALLOY: CONDUCTIVITY  $\geq 28\%$  IACS AT 20°C
- (N) 4. ALTERNATELY, 4X 0.05±0.03X45° CHAMFER CAN BE USED
5. BLEND RADIUS

TOLERANCES (UNLESS OTHERWISE SPECIFIED)			THIRD ANGLE PROJECTION	
DIMENSIONS ARE IN MILLIMETERS				
<i>USCAR-EWCAP</i>				
SCALE	DRAWN BY	CHECKED BY	DATE	
NONE	SHEIKH RAHMAN	C. DILLON	02/26/2025	
TITLE				
TERMINAL BLADE DETAIL				
SHEET	DRAWING NUMBER	SIZE	DO NOT SCALE DRAWING	REVISION LEVEL
2 of 9	EWCAP-001	A2	COMPUTER AIDED DRAWING	Z

064-T  
0.64 TERMINAL BLADE CONFIGURATION  
SCALE = 10:1

064-T001 - 2 BEAM APPLICATIONS  
(2 BEAM REFERS TO FEMALE TERM W/2 CONTACT SURFACES)

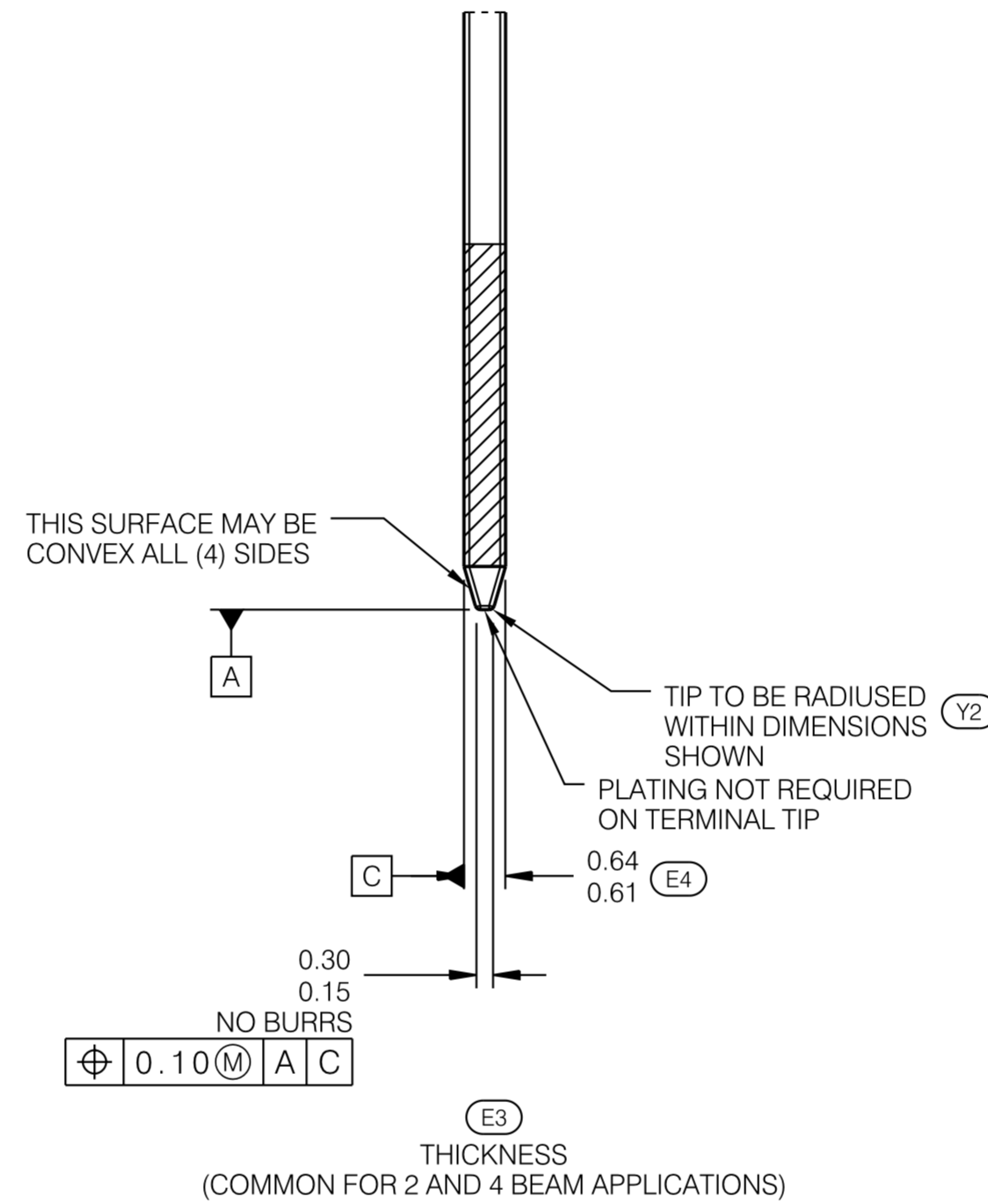
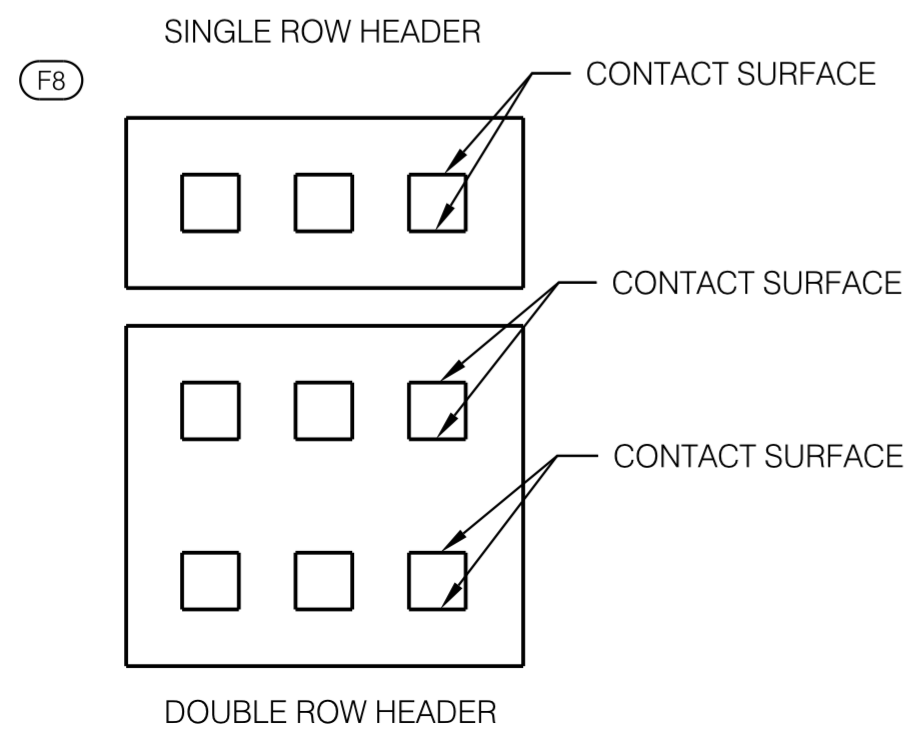
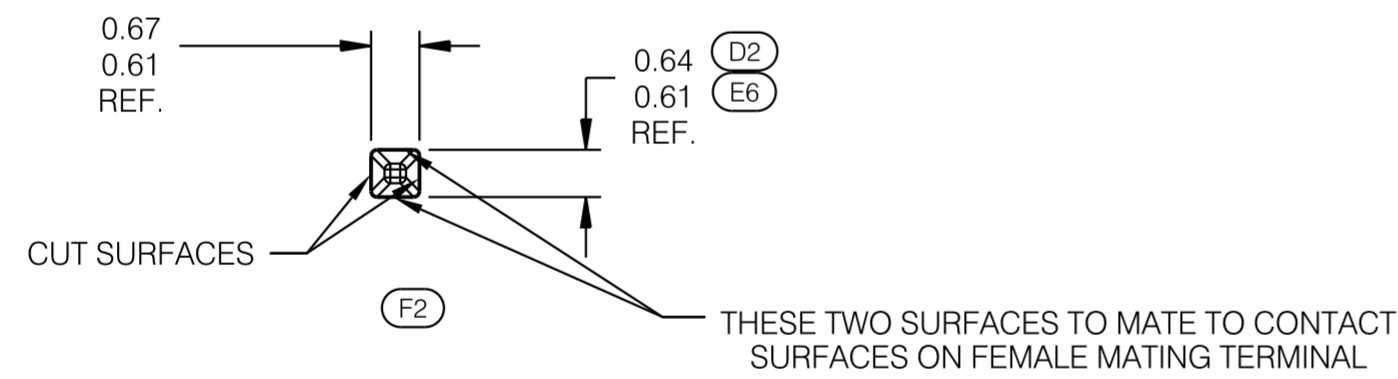
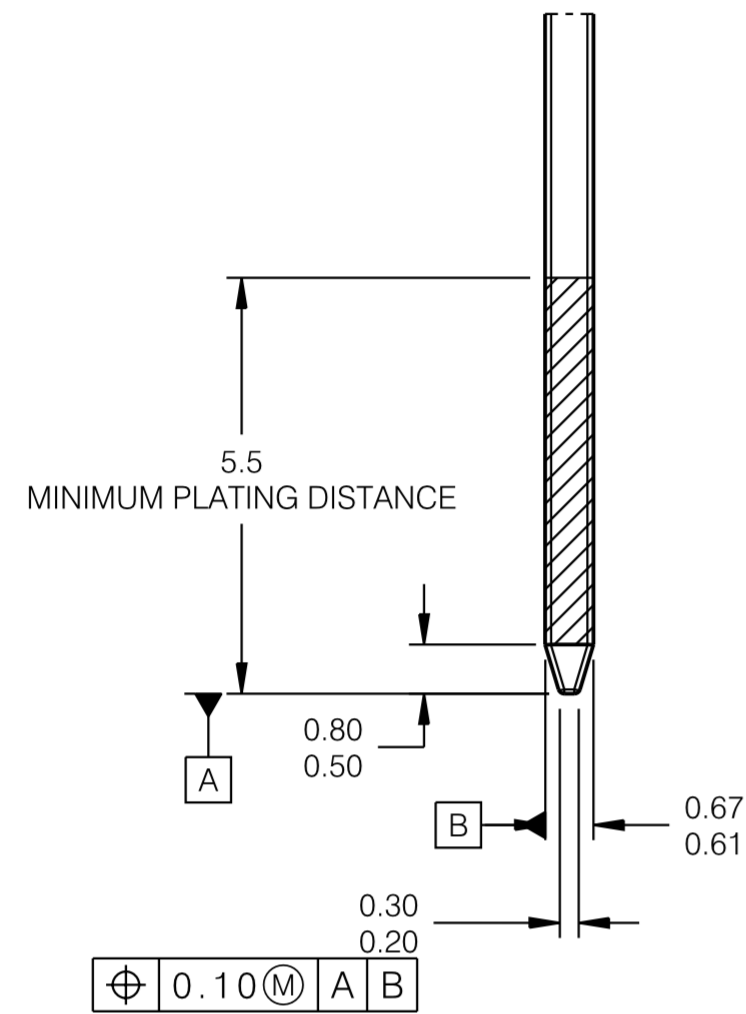

(E3)  
THICKNESS  
(COMMON FOR 2 AND 4 BEAM APPLICATIONS)

064-T002 - 2 OR 4 BEAM APPLICATIONS  
(SAME AS 2 BEAM APPLICATIONS EXCEPT FOR SHOWN DIMENSIONS)  
(4 BEAM REFERS TO FEMALE TERM W/ 4 CONTACT SURFACES)

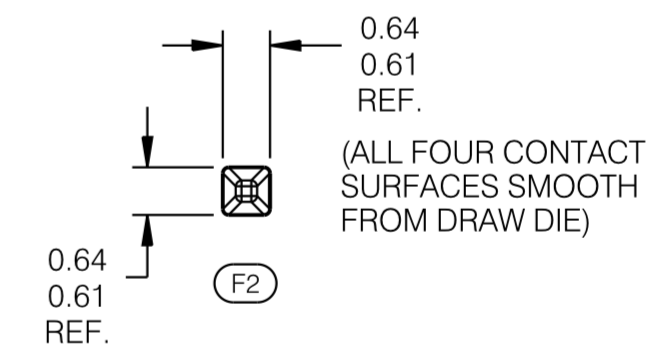
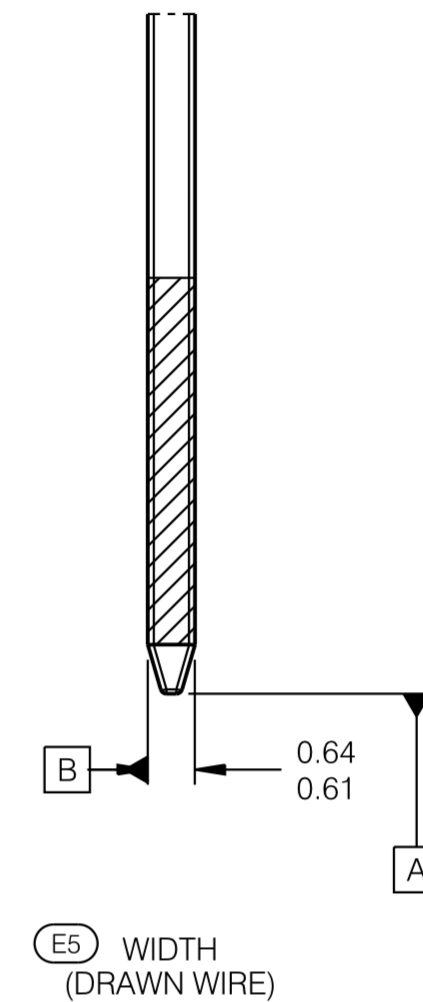

- (P)
- PIN MUST BE SYMMETRICAL WITHIN TOLERANCE SHOWN
  - ALL TIP OR PIN EDGES MAY BE RADIUSED - R0.08 MAX
  - NO BURRS ON TIP OR PIN EDGES
  - ALL PIN DIMENSIONS INCLUDE PLATING IF APPLICABLE
  - 064-T002: 0.64 MM X 0.64 MM SQUARE PINS MUST HAVE PLATING ON ALL SIDES

FOR ABS CONTROLLER APPLICATIONS, REFER TO THE ABS FOOTPRINTS SHOWN ON THE USCAR WEBSITE BECAUSE THEY SPECIFY A WIDTH AND THICKNESS THAT DEVIATE FROM THIS DRAWING.

TOLERANCES (UNLESS OTHERWISE SPECIFIED)		THIRD ANGLE PROJECTION	
DIMENSIONS ARE IN MILLIMETERS			
<i>USCAR-EWCAP</i>			
SCALE NONE	DRAWN BY SHEIKH RAHMAN	CHECKED BY C. DILLON	DATE 02/26/2025
TITLE TERMINAL BLADE DETAIL			
SHEET 3 of 9	DRAWING NUMBER EWCAP-001	SIZE A2	REVISION LEVEL Z
DO NOT SCALE DRAWING		COMPUTER AIDED DRAWING	

120-T  
1.20 TERMINAL BLADE CONFIGURATION  
SCALE = 10:1

120-T001 TAPERED BLADE

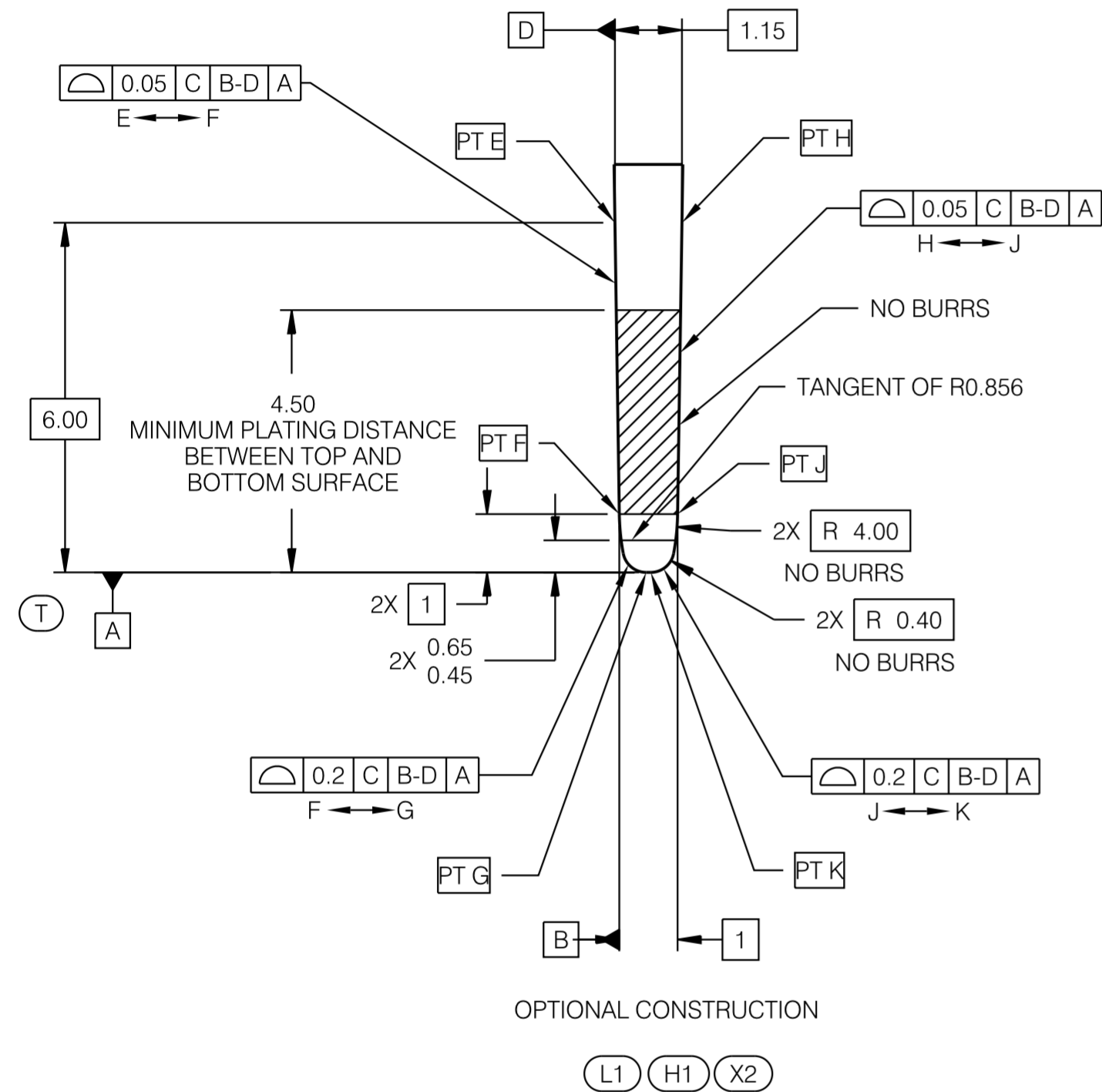

120-T002 STRAIGHT BLADE

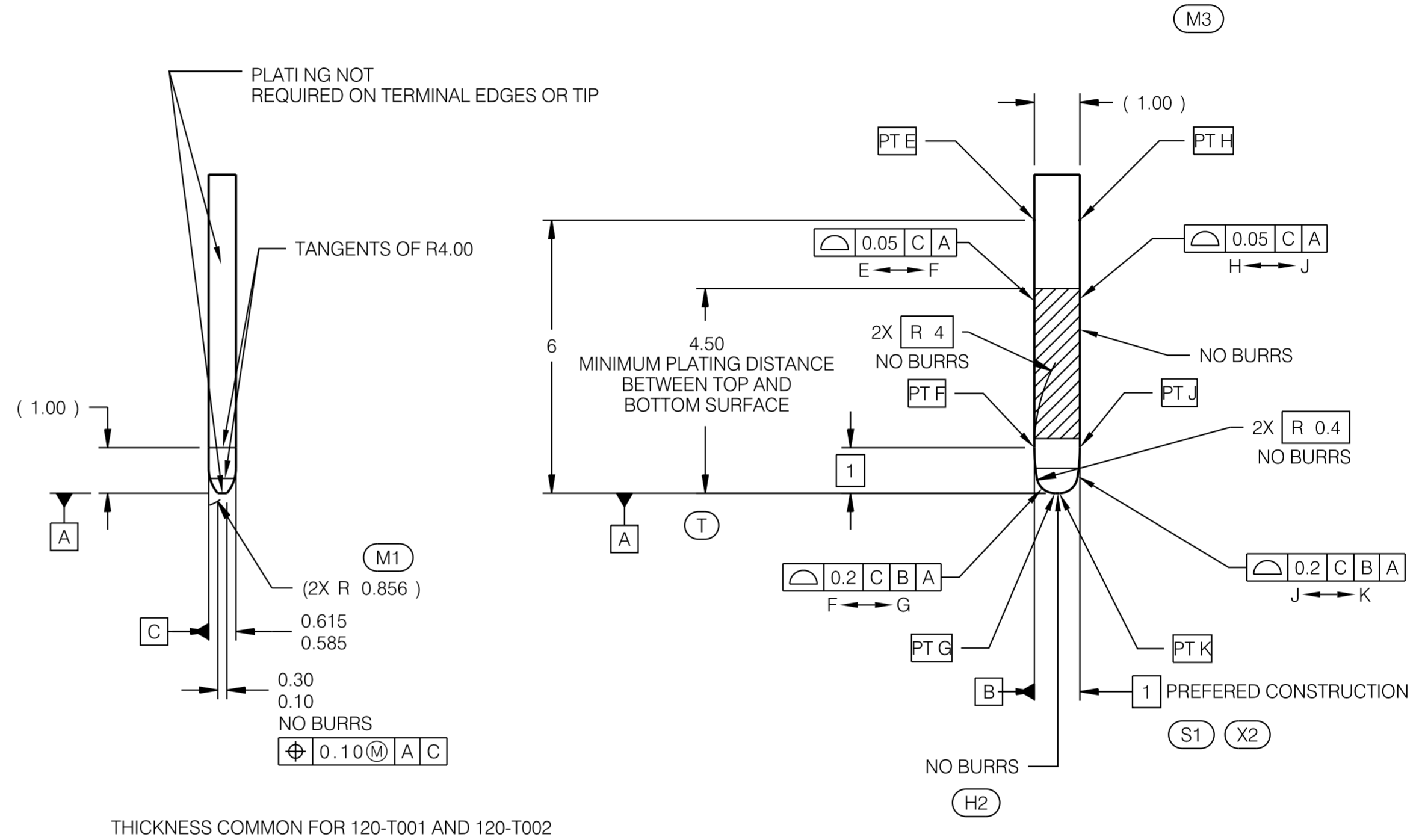

PLEASE NOTE THAT ON EXISTING DEVICES COMING FROM EUROPE (i.e. SENSORS AND SWITCHES) MAY HAVE MALE BLADES THAT DEVIATE FROM OUR PREFERRED CONSTRUCTION (120-T002) AND HAVE THE FOLLOWING DIMENSIONS: WIDTH: 1.20/0.95 mm & THICKNESS: 0.63/0.57 mm. CAUTION SHOULD BE TAKEN THAT MAKE TO FEMALE INTERFACES STILL MEET INSERTION EFFORTS AND ELECTRICAL REQUIREMENTS AS SPECIFIED IN THE PERFORMANCE TEST SPECIFICATIONS.

(M2)

TOLERANCES (UNLESS OTHERWISE SPECIFIED)		THIRD ANGLE PROJECTION	
DIMENSIONS ARE IN MILLIMETERS			
<i>USCAR-EWCAP</i>			
SCALE NONE	DRAWN BY SHEIKH RAHMAN	CHECKED BY C. DILLON	DATE 02/26/2025
TITLE TERMINAL BLADE DETAIL			
SHEET 4 of 9	DRAWING NUMBER EWCAP-001	SIZE A2	REVISION LEVEL Z

150-T001  
1.50 TERMINAL BLADE CONFIGURATION  
SCALE = 10:1

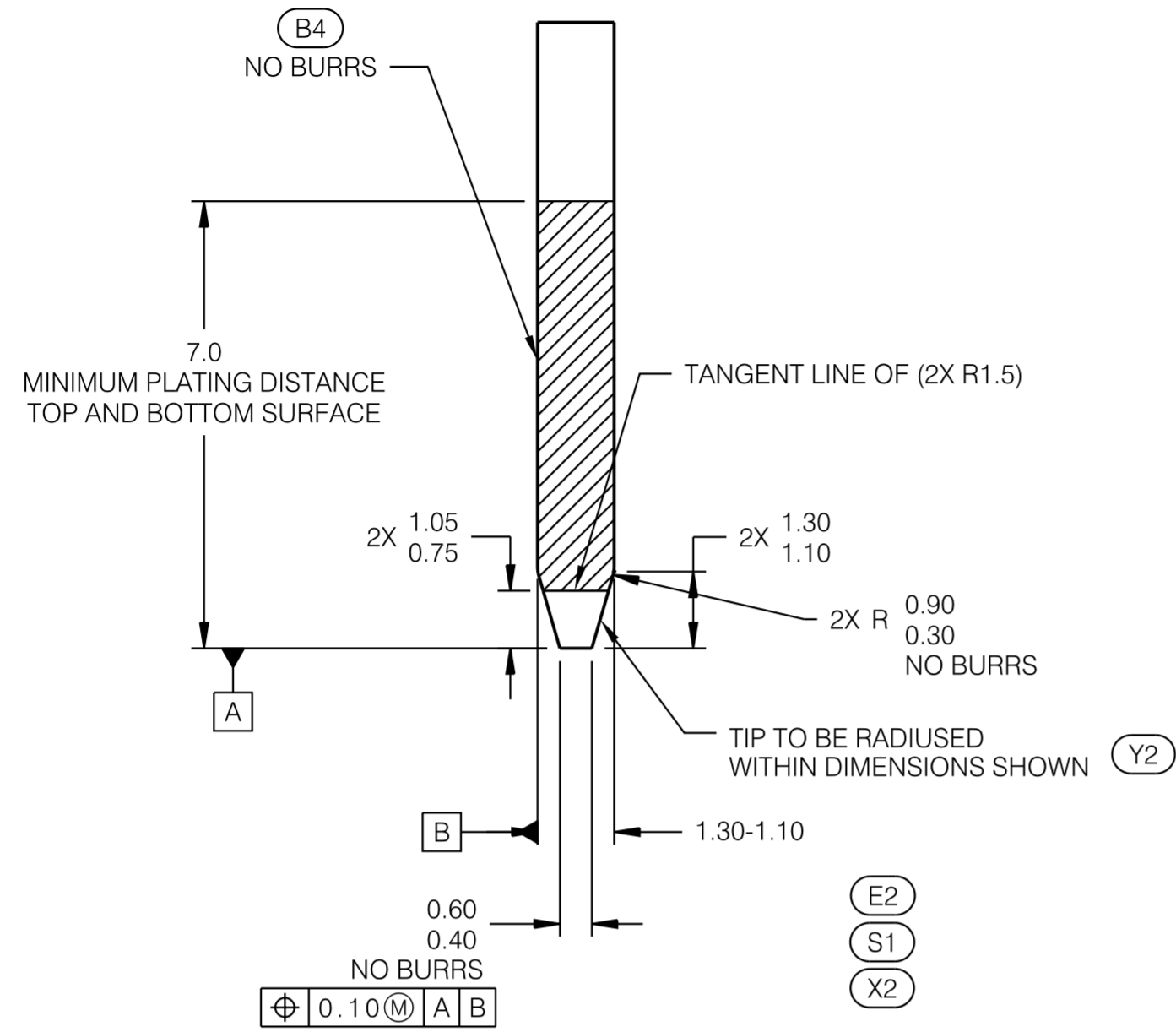

PLATING NOT REQUIRED ON  
TERMINAL EDGES OR TIP

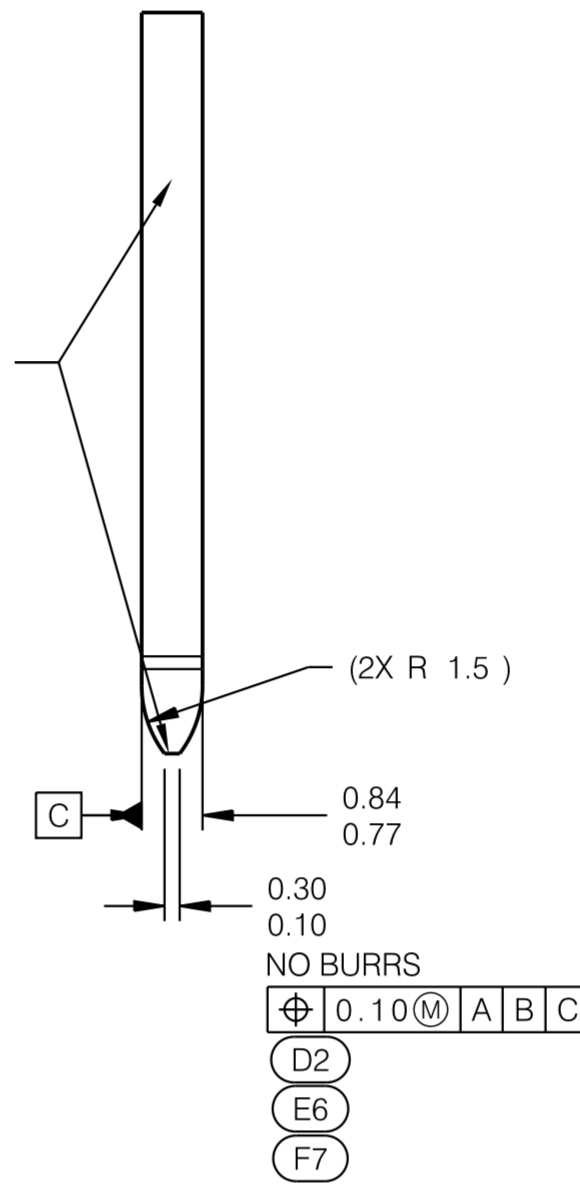

280-T001  
2.80 TERMINAL BLADE CONFIGURATION  
SCALE = 10:1

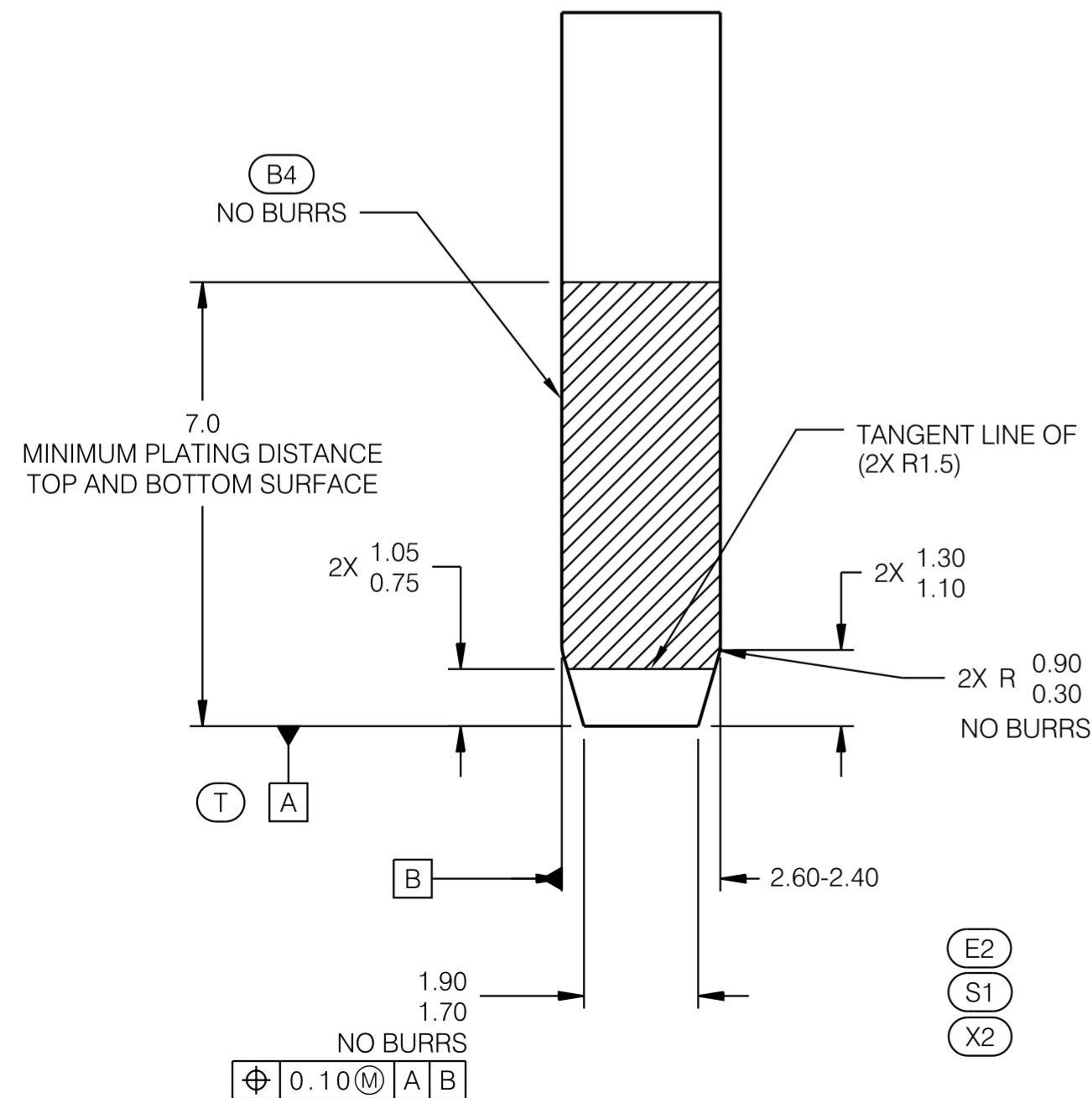

PLATING NOT REQUIRED ON  
TERMINAL EDGES OR TIP

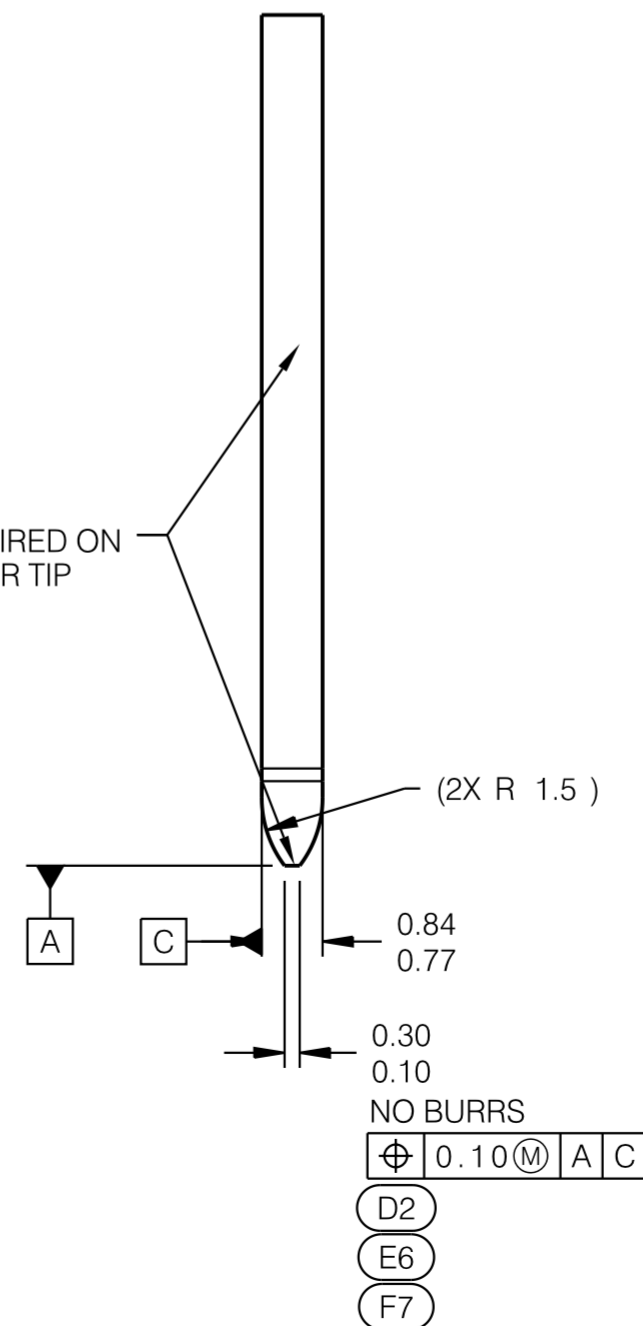

TOLERANCES (UNLESS OTHERWISE SPECIFIED)				THIRD ANGLE PROJECTION	
DIMENSIONS ARE IN MILLIMETERS					
<i>USCAR-EWCAP</i>					
SCALE	DRAWN BY	CHECKED BY	DATE		
NONE	SHEIKH RAHMAN	C. DILLON	02/26/2025		
TITLE					
TERMINAL BLADE DETAIL					
SHEET	DRAWING NUMBER	SIZE	DO NOT SCALE DRAWING	REVISION	LEVEL
5 of 9	EWCAP-001	A2	COMPUTER AIDED DRAWING	Z	

630-T001  
 6.30 TERMINAL BLADE CONFIGURATION  
 SCALE = 10:1

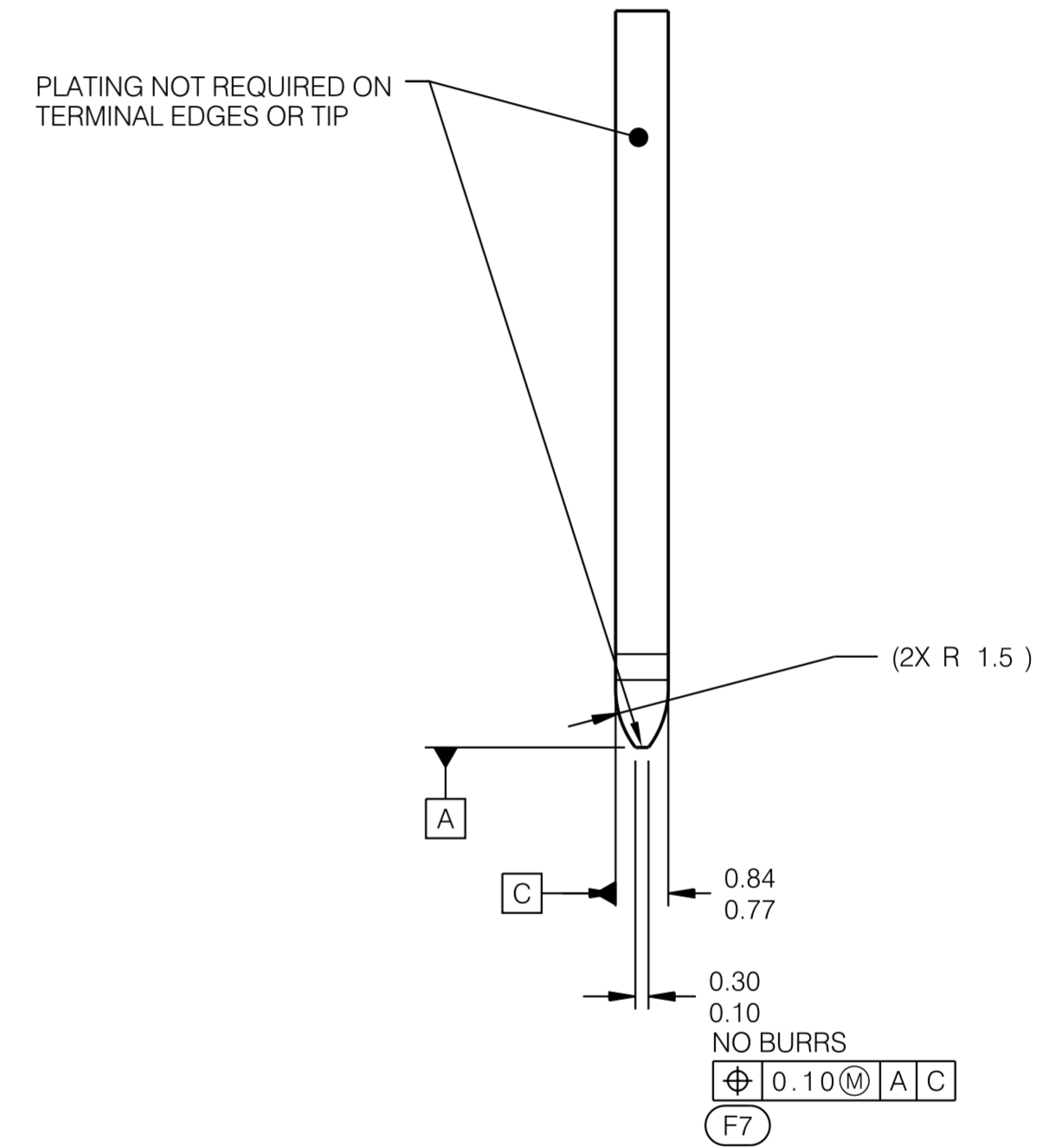
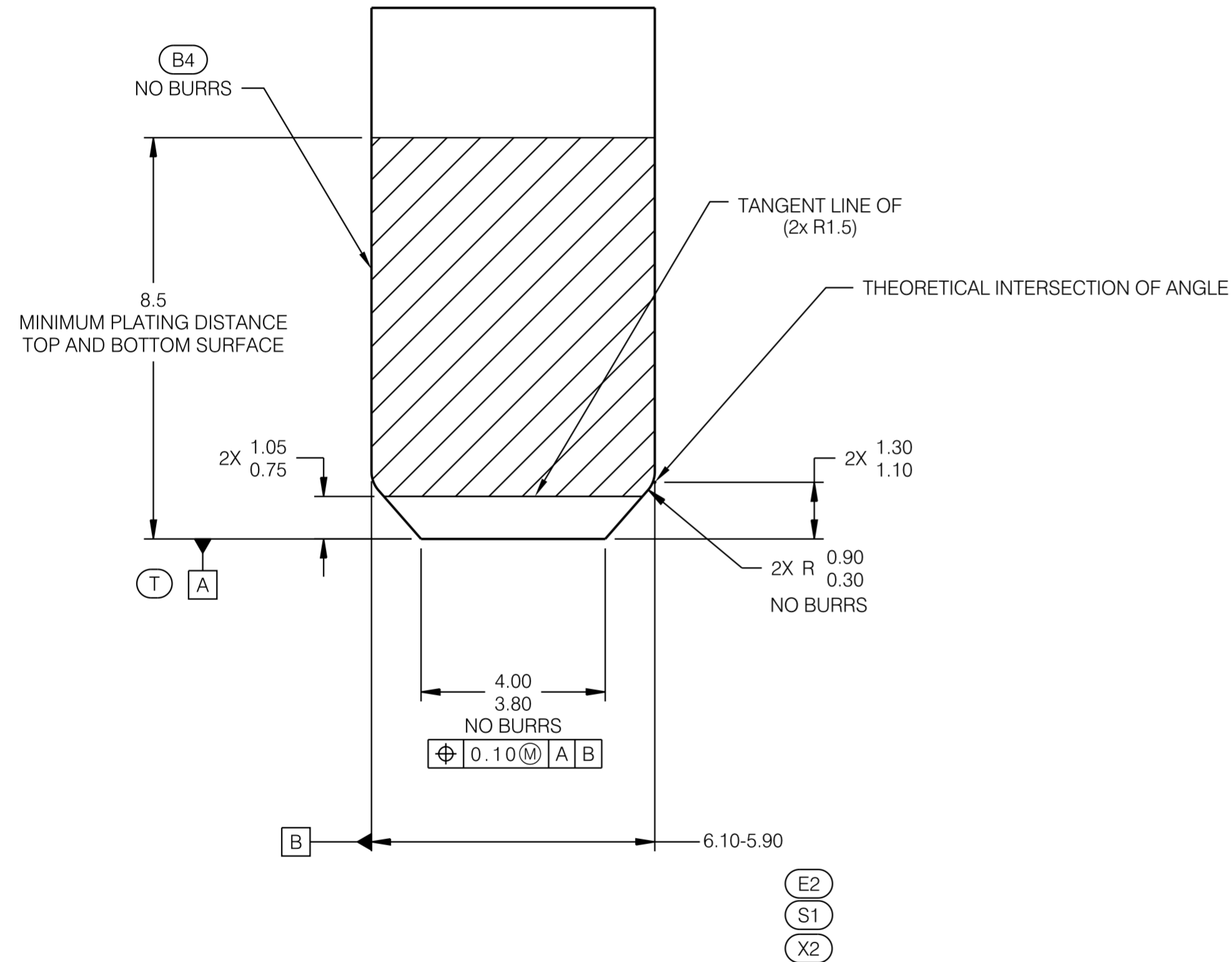

TOLERANCES (UNLESS OTHERWISE SPECIFIED)		THIRD ANGLE PROJECTION	
DIMENSIONS ARE IN MILLIMETERS			
<i>USCAR-EWCAP</i>			
SCALE NONE	DRAWN BY SHEIKH RAHMAN	CHECKED BY C. DILLON	DATE 02/26/2025
TITLE TERMINAL BLADE DETAIL			
SHEET 6 of 9	DRAWING NUMBER EWCAP-001	SIZE A2	REVISION LEVEL Z

950-T001  
 9.50 TERMINAL BLADE CONFIGURATION  
 SCALE = 10:1

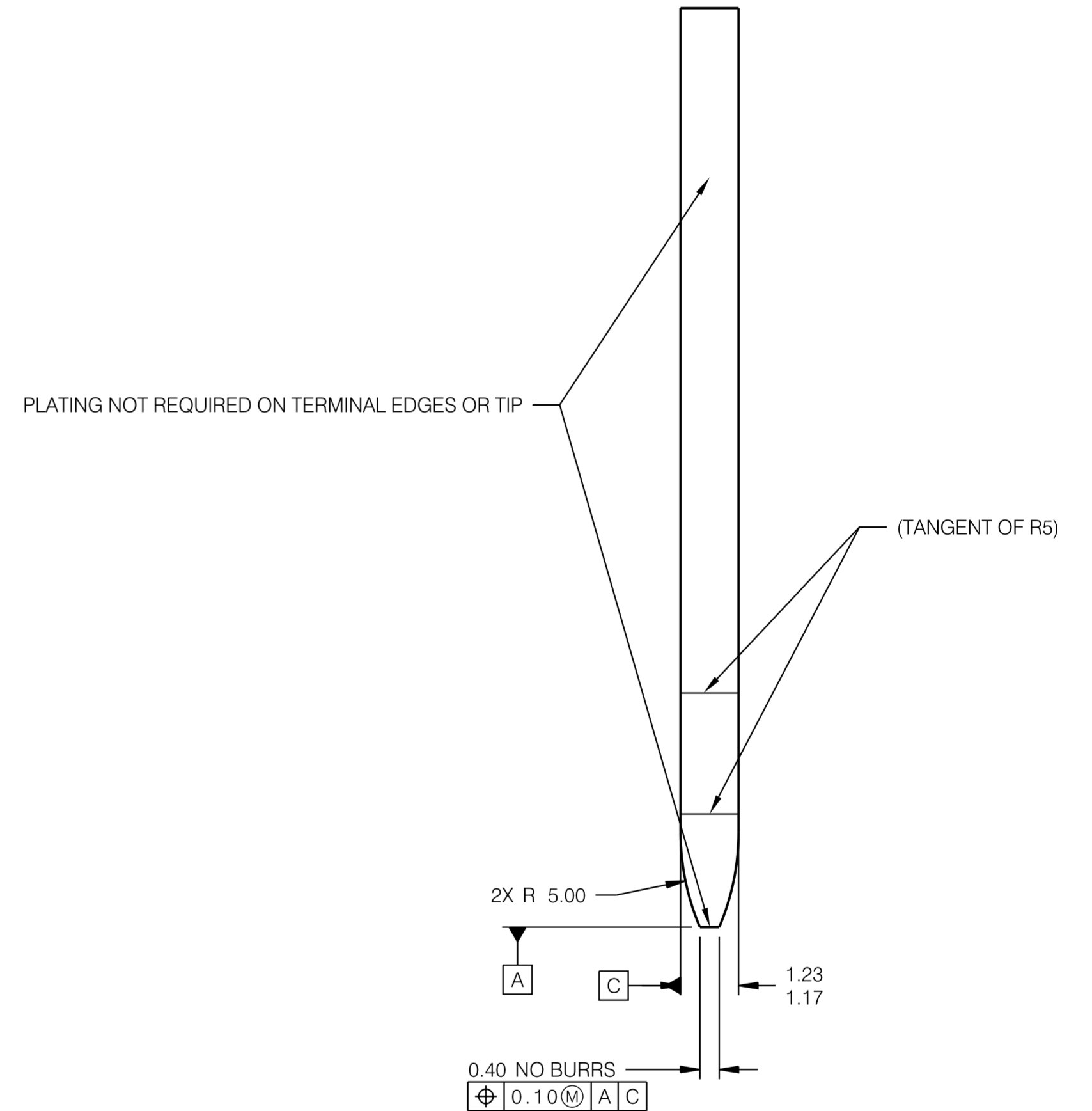
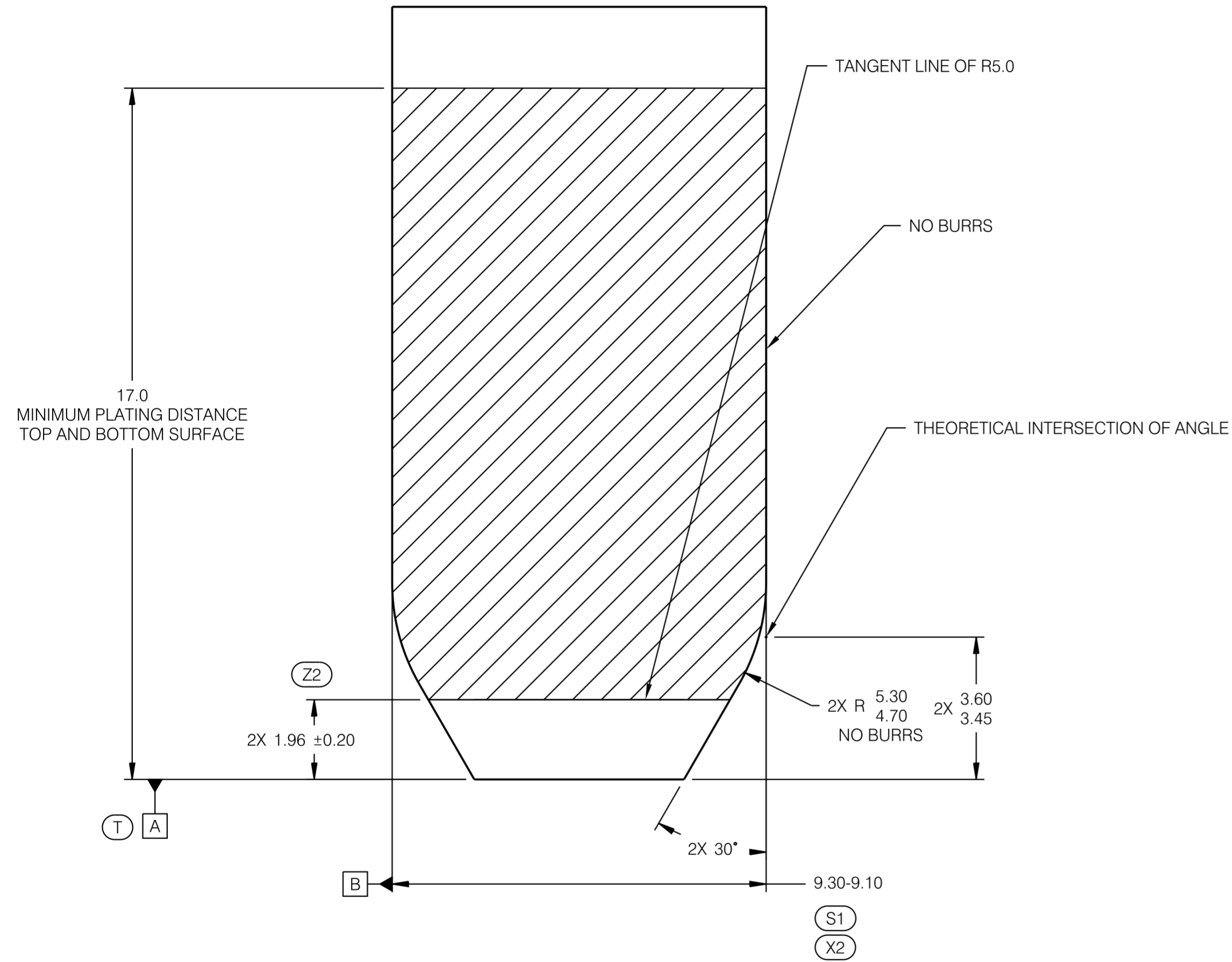

TOLERANCES (UNLESS OTHERWISE SPECIFIED)		THIRD ANGLE PROJECTION	
DIMENSIONS ARE IN MILLIMETERS			
<i>USCAR-EWCAP</i>			
SCALE NONE	DRAWN BY SHEIKH RAHMAN	CHECKED BY C. DILLON	DATE 02/26/2025
TITLE TERMINAL BLADE DETAIL			
SHEET 7 of 9	DRAWING NUMBER EWCAP-001	SIZE A2	DO NOT SCALE DRAWING COMPUTER AIDED DRAWING REVISION LEVEL Z

1450-T001  
14.5 TERMINAL BLADE CONFIGURATION  
SCALE = 10:1

(Z1)

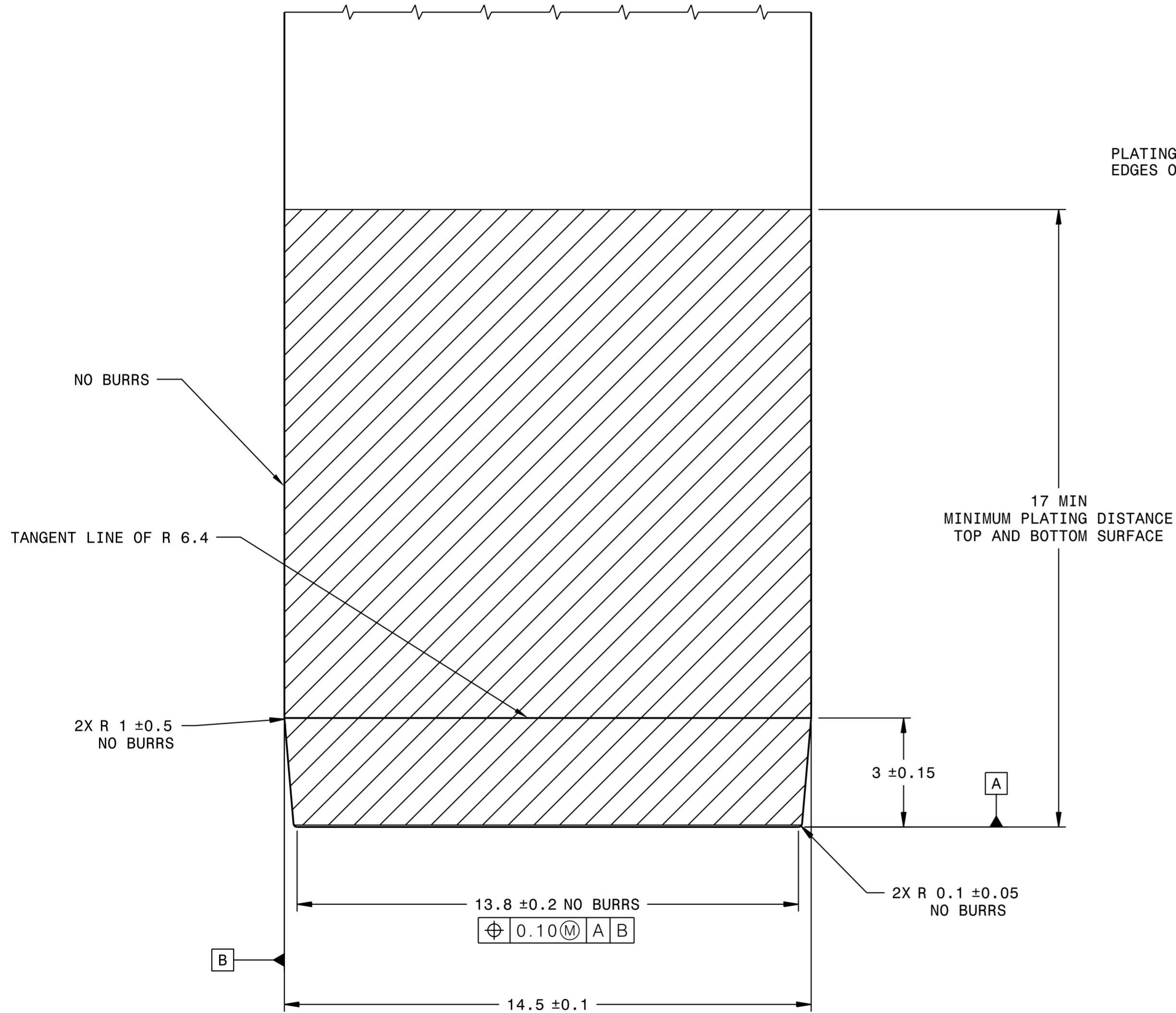

PLATING NOT REQUIRED ON  
EDGES OR TIP

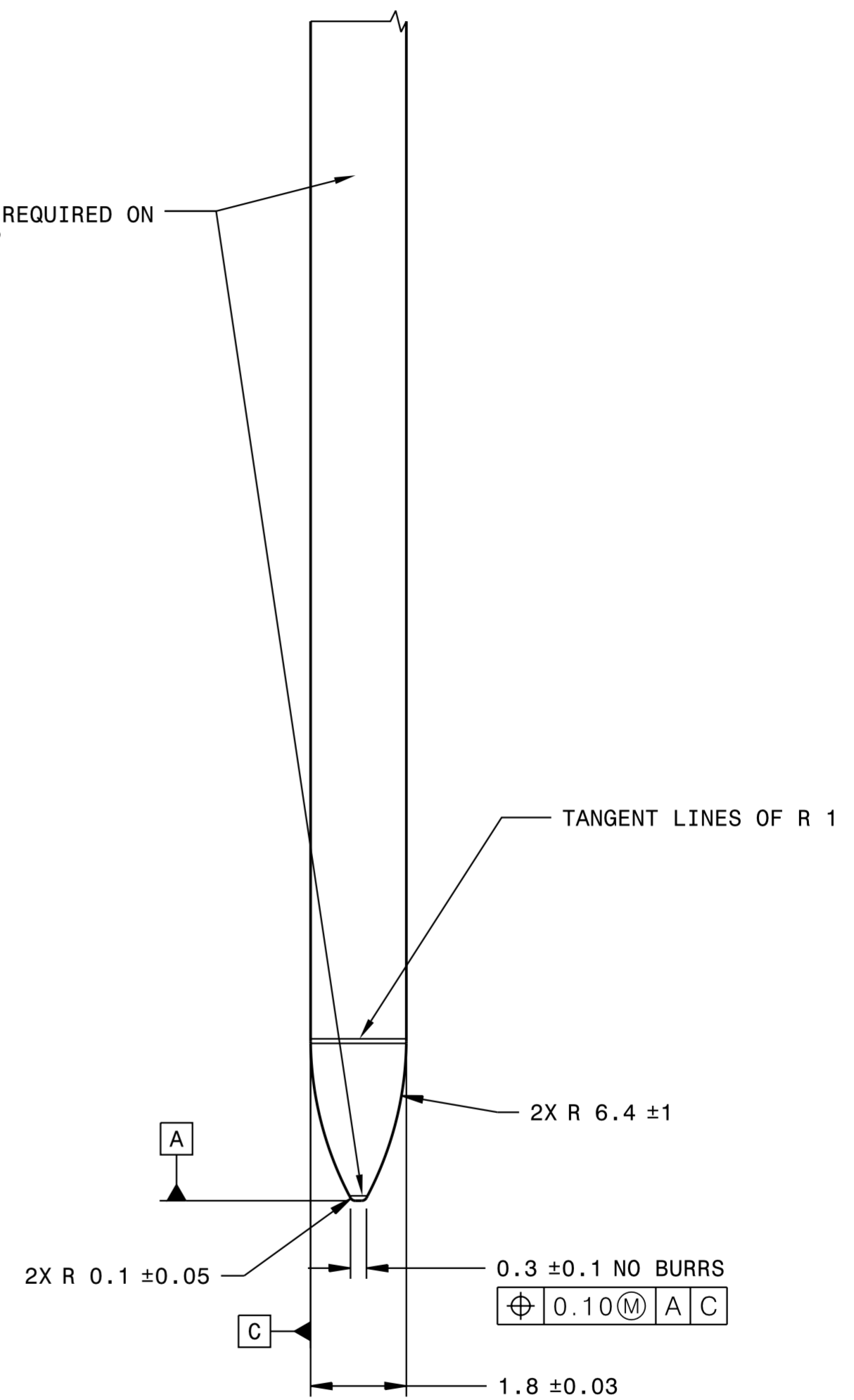

TOLERANCES (UNLESS OTHERWISE SPECIFIED)  
DIMENSIONS ARE IN MILLIMETERS

THIRD ANGLE PROJECTION

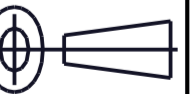

USCAR-EWCAP

SCALE NONE	DRAWN BY SHEIKH RAHMAN	CHECKED BY C. DILLON	DATE 02/26/2025
---------------	---------------------------	-------------------------	--------------------

TITLE  
TERMINAL BLADE DETAIL

SHEET 8 of 9	DRAWING NUMBER EWCAP-001	SIZE A2	DO NOT SCALE DRAWING COMPUTER AIDED DRAWING	REVISION LEVEL Z
-----------------	-----------------------------	------------	--	------------------------

## USCAR Device Side Male Blade Plating Chart

Plating Process	Temp Class max.	Vibe Class max.	Layer	Material & Thickness
Tin (Hot Dip) HALT	II	1	Top Plating	0.76 to 2.5 $\mu$ m Tin (No Lead). Base Material $\geq$ 5% Zinc Content
	III	1	Top Plating	0.76 to 2.5 $\mu$ m Tin (No Lead). Base Material $<$ 5% Zinc Content
Tin (Electrodeposited)	III	2	Underplate	0.5 to 2.0 $\mu$ m Nickel or Copper. Base Material is $\geq$ 5% Zinc Content . See Note 1
			Top Plating	0.76 to 1.5 $\mu$ m Tin (No Lead) (Reflow)
	III	2	Top Plating	0.76 to 1.5 $\mu$ m Tin (No Lead) (Reflow) Base Material $<$ 5% Zinc Content
	III	2	Underplate	0.76 to 2.0 $\mu$ m Nickel . See Note 1
			Top Plating	1.0 to 2.5 $\mu$ m Tin (No Lead)
Silver (Electrodeposited)	IV	3	Underplate	1.0 to 2.0 $\mu$ m Nickel. See Note 1
			Top Plating	1.0 to 3.0 $\mu$ m Silver with Anti-Tarnish Coating (Thiol or Equiv.) Purity of Silver is 99.9% min. and the Finish is Semi-Bright Hardness = 90-130 HK (No Chromates) Refer to ASTM B700, Type 1 (W1)
	IV	4	Underplate	1.0 to 2.0 $\mu$ m Nickel. See Note 1
			Top Plating	4.0 to 6.0 $\mu$ m Silver with Anti-Tarnish Coating (Thiol or Equiv.) Purity of Silver is 99.9% min. and the Finish is Semi-Bright Hardness = 90-130 HK (No Chromates) Refer to ASTM B700, Type 1 (W1)
Tin/Silver (Hot Dip)	IV	2	Top Plating	1.0 to 3.0 $\mu$ m (Silver Range 3.7% to 5.5%) No Anti-Tarnish Coating Required
Gold (Electrodeposited)	IV	3	Underplate	1.0 to 2.0 $\mu$ m Nickel. See Note 1
			Top Plating	0.76 to 2.0 $\mu$ m Hard Gold. Purity of Gold is 99.7% min. Hardness = 130-200 HK Refer to ASTM B488, Type I, Code C (W2)

Note 1 - Nickel Deposit  $<$  8,000 psi internal stress (Can be met by using sulfamate nickel process) (W3)

(T) Note 2 - Refer to USCAR-2 for details regarding temperature class and vibration profiles.

(W4)

TOLERANCES (UNLESS OTHERWISE SPECIFIED)		DIMENSIONS ARE IN MILLIMETERS		THIRD ANGLE PROJECTION 
<i>USCAR-EWCAP</i>				
SCALE NONE	DRAWN BY SHEIKH RAHMAN	CHECKED BY C. DILLON	DATE 02/26/2025	
TITLE <b>TERMINAL BLADE DETAIL</b>				
SHEET 9 of 9	DRAWING NUMBER EWCAP-001	SIZE A2	DO NOT SCALE DRAWING COMPUTER AIDED DRAWING	REVISION LEVEL Z