

# *DRAWING REQUIREMENTS FOR DEVICE CONNECTOR DRAWINGS*

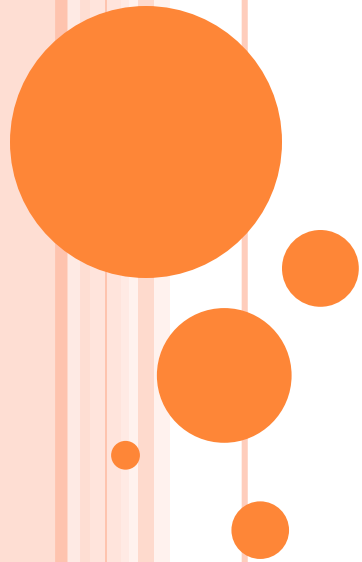

# *HOW TO USE EWCAP DRAWING / DRAFTING REQUIREMENTS*

- This document is to be used to check newly-released drawings for use by EWCAP. Confirm compliance by confirming each of the requirements listed. Use the Checklist Summary Sheet (Appendix E) to verify drawing is ready to be sent to USCAR.
- Older designs are not expected to be revised to this format. At the time an existing drawing is being revised it will be evaluated to determine if the format should be brought up to the latest drafting standard.
- Drawing authors should contact the EWCAP projects group if variances are needed.
- General Motors, Ford and FCA US have agreed to accept drawings in the format listed. Design errors are possible if this method is not used.

# CONTENTS

1. General EWCAP Drawing/Drafting Requirements
2. Blade Location Labeling and Plan View Orientation
3. Datum Feature “A”
4. Datum Features of Size “B and C”
5. Connector Floor
6. Packaging views
7. Standard notes
8. Blade Depth
9. Default tolerances
10. Supplier Logo
11. Method for showing draft
12. Color/index/part number table
13. Appendix
  1. A – Template / Title Block Example
  2. B – Standard Notice
  3. C – Additional deliverables with drawing submission
  4. D – Legal Notice
  5. E – Check Sheet for confirming compliance

# GENERAL EWCAP DRAWING / DRAFTING REQUIREMENTS

- Req.#1 Part Number used is the next part number available in the category per (<http://ewcap.uscarteams.org/ConnectorCatalog.htm#PartNumSys>). Note: Physical changes to parts that make them incompatible with previous revisions require new part numbers (i.e. 150-S-004-2-Z01 becomes 150-S-004-2-Z02).
- Req.#2 Deliverables for data format and related information per Appendix C are supplied.
- Req.#3 Where not controlled by the drawing guideline, the Geometric Dimensioning and Tolerancing standard ASME Y14.5M-2009 or latest revision is followed.
- Req.#4 Drawing size is A2 = 420 x 594 paper with 10mm border actual drawing space is 400 x 574. If additional drawing space is required use multiple sheets.
- Req.#5 Supplier name (and optional logo) are shown on the drawing. The supplier identification box is located to the left of the title block above the part number schedule.
- Req.#6 The drawing may consist of multiple sheets: The first sheet will show the interface detail, note field and revision table (Note: Revisions level are always letters. Alpha I, O, and Q are not used.) Unless space constrained, Notes will be placed on the right center of Page 1, the left side of Page one will show keying details; the upper right corner of Page 1 will have an isometric view; the upper center area of Page 1 will show the two packaging views. Additional sheets may contain the clearance envelope graphics and dimensions, optional construction. The last sheet will contain the signed and dated legal notice similar to shown in Appendix E.
- Req.#7 Template / Title block must be used as shown in Appendix A. DXF & DWG formats are available at the USCAR-EWCAP website.
- Req.#8 Standard notice as shown in Appendix B is present in the upper right hand corner of the drawing.
- Req.#9 Review and obtain approval for any deviation from the USCAR/EWCAP footprint drawing requirements with the EWCAP/OEM projects committee. EWCAP drawings require approval by a simple majority of the participating OEMs. No single OEM partner has priority on approval. Projects committee will issue a change number that must be shown on the title block.
- Req.#10 Critical or important dimensions are controlled with specific tolerances and detailed in the view best suited to describe the feature being controlled.
- Req.#11 Where clarification is needed as to how the part is measured, confirm applicable SPC, gauging or layout requirements are shown in the note field.

# DRAFTING REQUIREMENTS

- ❑ Req. #28 (Font)
  - Font Type = Standard
  - 3mm Character Height for Dimensions, Notes, View, Line and Point Callout ie; SECTION A-A VIEW A
  - 5mm Character height for View, Line and Point Designations ie; SECTION A-A
  
- ❑ Req. #29 (Line Type and Weight)
  - Dimension Lines = Continuous .35 mm
  - Extension lines = Continuous .35 mm
  - Extension line Offset = 0.25 mm
  - Leader Lines = Continuous .35 mm
  - Object lines = Continuous .50 mm
  - Cross Hatch Lines = Continuous .35 mm
  - Arrow heads = Continuous .35 mm, filled, approximate ratio is 3:1 Length x Width
  - Section Designation = Phantom .35 mm
  
- ❑ Req. #30 (Revision Table and Balloons)
  - Font Type = Standard
  - For initial release of drawings the Revision Record shall read A. The revision level in the title block shall be A and the letter column of the Revision table shall read A.
  - For subsequent revisions start with the letter B . The letter column of the revision table could be A1 through A9 the Revision Level of the title block would say A the next set of changes would start with B. Refer to the example below.
  - 3mm Character Height for rev balloons Refer to the example below.
  - Revisions shall be designated as an alphanumeric set of characters that correspond to the designations shown in the letter column of the revision table Revision records will always start with a word such as was, removed, or added. Revision record of the rev column shall state what the previous information was.
  - Rev balloons shall be placed near the dimension or note that was changed, removed or added.

# DRAWING REVISIONS

□ Req. #30

Balloon on drawing indicates change.  
Corresponding number in revision record describes change

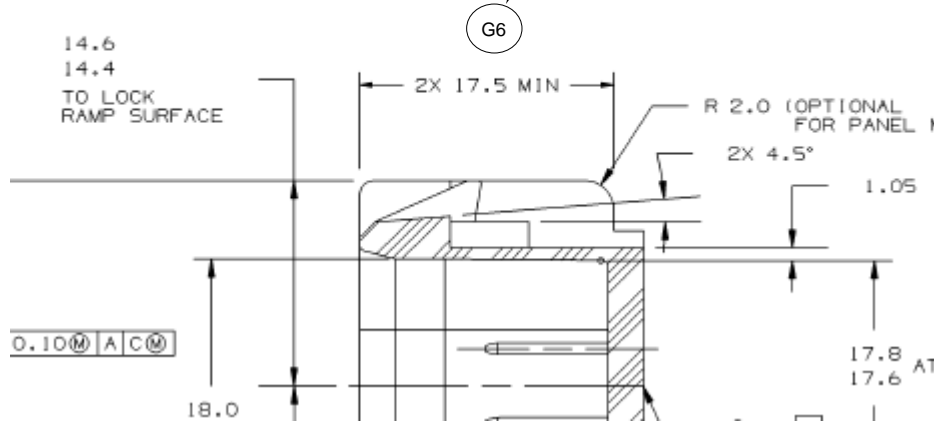

030	H	WAS 8.0	03NW03	JC	JJ
G9		EDIT DRAWING TO CONFORM WITH LATEST USCAR SPECIFICATION			
G8		REMOVED NOTICE			
G7		ADDED NOTE 8 AND 9			
		NOTE 5 WAS NOTE 6			
		NOTE 6 WAS NOTE 7			
		ADDED 1" DRAFT TO NOTE 7			
G6		WAS 18.2/17.6			
		REMOVED DIM. 21.0			
		SEC. B-B, ADDED (6.95), ADDED NOTE TO LOCK RAMP SURFACE TO DIM 10.65/10.45			
G5		ADDED NOTE TO 15.0 AT DATUM G			
		REMOVED BASE DIM FROM 2.5, 6.0			
		SEC. C-C, ADDED DIM 1.95, 15° WAS 17°/15°			
G4		PLAN VIEW- ADDED DIM 2X 6.05 TO SLOT SURFACE			
G3		ADDED DIM. 8.0 MIN.			
		PACKAGE VIEW- MOVED DIMS TO TOP VIEW			
		REMOVED "MINIMUM" FROM NOTE			
G2		ADDED DIM. 3 X 7.65			
		ADDED BLADE DIM			
019	G1	MOVED 45° FROM SEC. A-A TO DETAIL VIEW E	24MR03	JC	JJ
018	F	SEE CHANGE NOTICE	21FE03	JC	JJ
014	E	SEE CHANGE NOTICE	23JA03	JC	JJ
011	D	REMOVED TERMINAL DIM. AND ADDED NOTE B.	150C02	JC	JJ
		21.0 WAS 20.7			
007	C	UPDATE FORMAT TO LATEST USCAR STANDARDS	29AP02	JC	JJ
		REMOVED Ⓢ ON FACE VIEW, SECTION A-A, AND SECTION C-C			
		REMOVED "NO BURRS" NOTE ±1.70 DIM			
003	B	note #2 0.0005MM (20μ-INCHES) WAS 0.001MM (40μ-INCHES)	17JL01	JC	JJ
	A	INITIAL RELEASE	09MR00	UVH	JJ
CHANGE SERIAL NUMBER	LET	REVISION RECORD	DATE	DWN	CHK

USCAR Change Notice  
Serial number

Drawings are released  
at Rev. A

# BLADE LOCATION LABELING AND PRIMARY VIEW ORIENTATION

Req. #12 Interface Orientation with Blade Location and pitch and row-to-row distance confirms to EWCAP preferences.

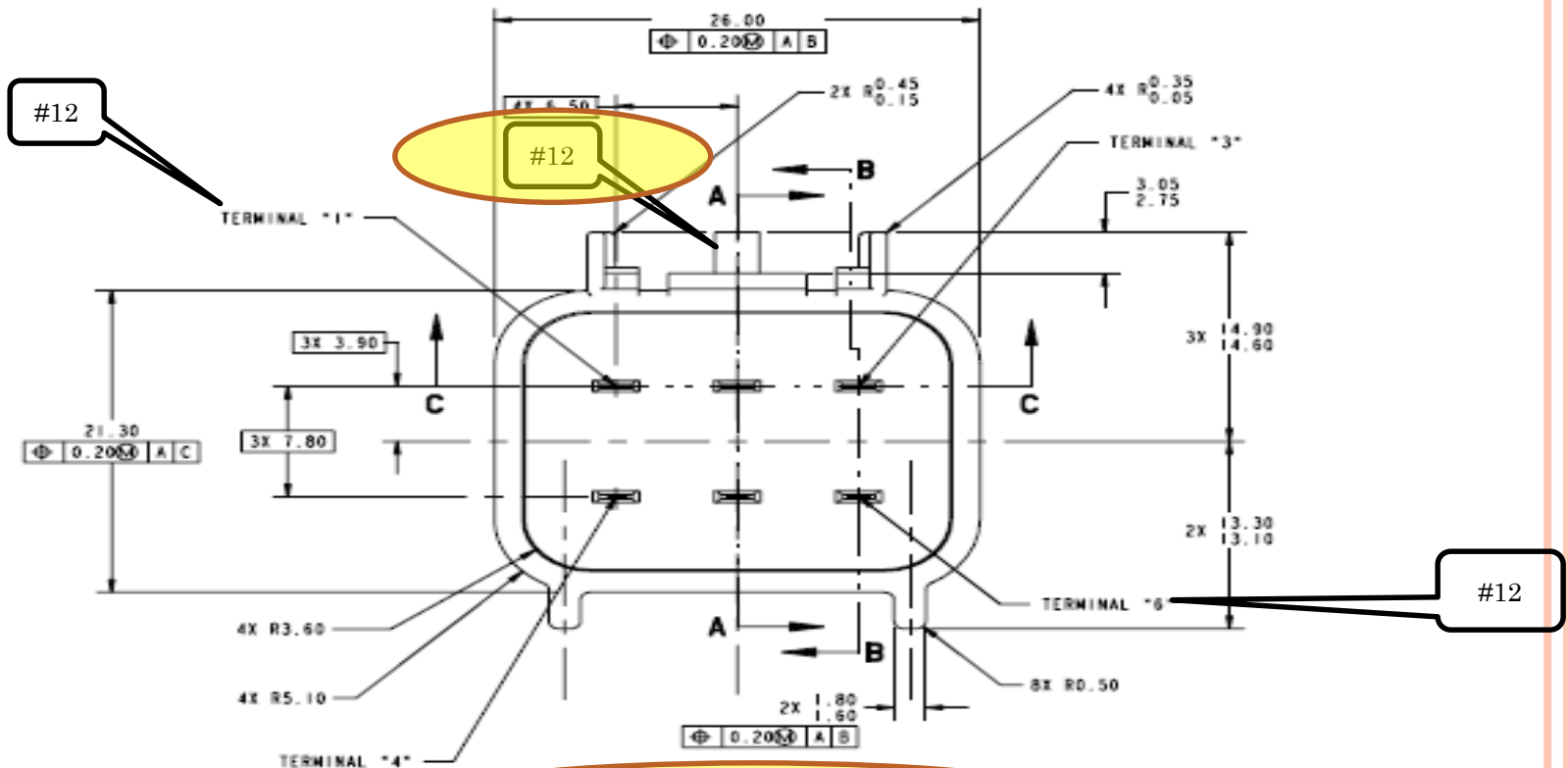

Label the corner blade locations as shown. The interface primary view is to be oriented with the latch feature at the top, looking into the footprint at the tips of the male blades, number 1 is in the upper left corner. The last number position is the lower right in the field. Each row of terminals are numbered left to right. Follow USCAR-12 Appendix A for non-standard terminal layouts. Blade center planes must be per the EWCAP guidelines unless an engineering reason exists for a variance..

# DATUM “A”

□ Req. #13 - Datum A

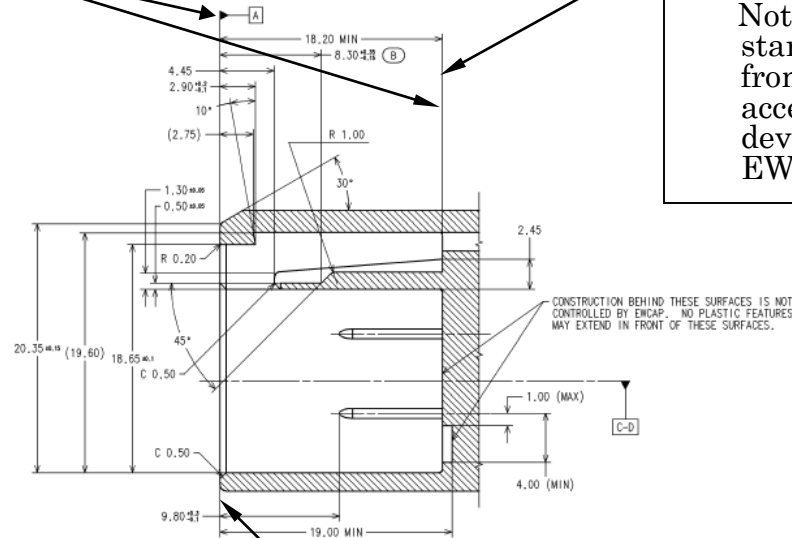

For **Un-Sealed** Connectors Datum A is always the floor of the connector. The stop point reference for the mating connector is this surface. Show distance to “front Face”, “lock face” and blade tip from -A- in this view. Design should incorporate 4 datum targets raised 0.375. Located in the 4 corners of the pocket.

Note: Where existing drawing or design standards such as ISO or VDA differ from this datum system, it may be acceptable to use those standards. If a deviation is necessary contact the EWCAP/OEM projects committee.

Sealed Connector Datum scheme shown for reference

For **Sealed** Connectors Datum A is always this face of the connector. The stop point reference for the mating connector is this surface. Show distance to “floor”, “lock face” and blade tip from -A- in this view.

Note: Where existing drawing or design standards such as ISO or VDA differ from this datum system, it may be acceptable to use those standards. If a deviation is necessary contact the EWCAP/OEM projects committee.



# DATUMS “B” AND “C” FOR NON ELLIPTICAL SHAPES

- ❑ Req. # 14 Datum B is the primary shroud length (interior). The datum marker is on the left-interior surface.
- ❑ Req. # 15 Datum C is the width (interior). The datum marker is on the lower-interior surface.
- ❑ Req. # 16 Terminal spacing is basic from datum B and C centerlines.
- ❑ Req. #17 Profile tolerance is used to define the shroud interior.  
Draft is specified as “within tolerance” No specific draft is defined.

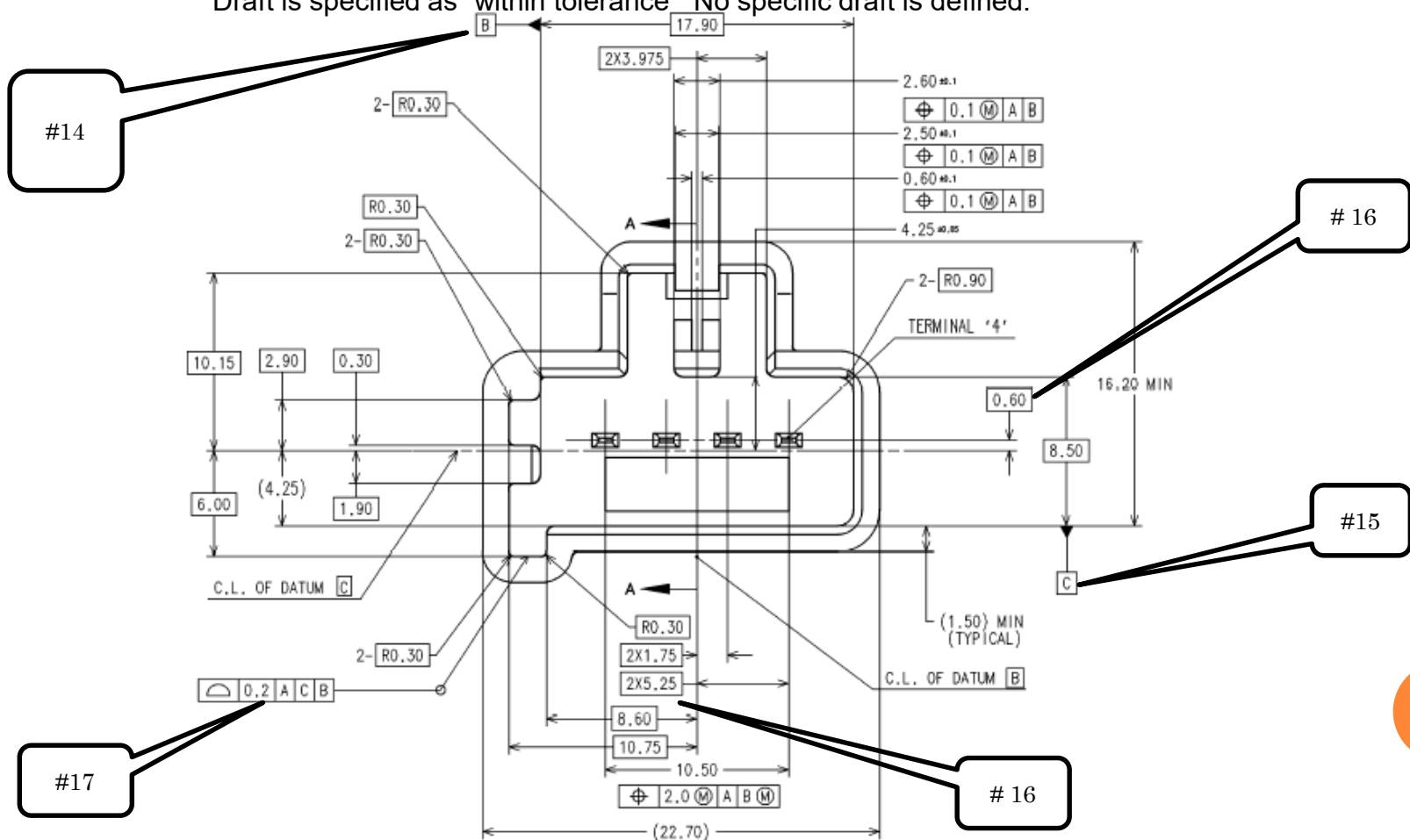

# DATUMS “B” AND “C” FOR SEALED ELLIPTICAL SHAPES

- ❑ Req. # 14 Both X and Y Datum center planes are established by the actual part profile of the shroud interior.
  - ❑ Req. # 15 The datum marker is below the profile Callout
  - ❑ Req. # 16 Terminal spacing is basic from datum B and C centerlines.
  - ❑ Req. #17 Profile of a Surface or Line tolerance is used to define the shroud interior and datum planes.
- The part profile establishes both X&Y center planes. Refer to ASME Y14.5-2009

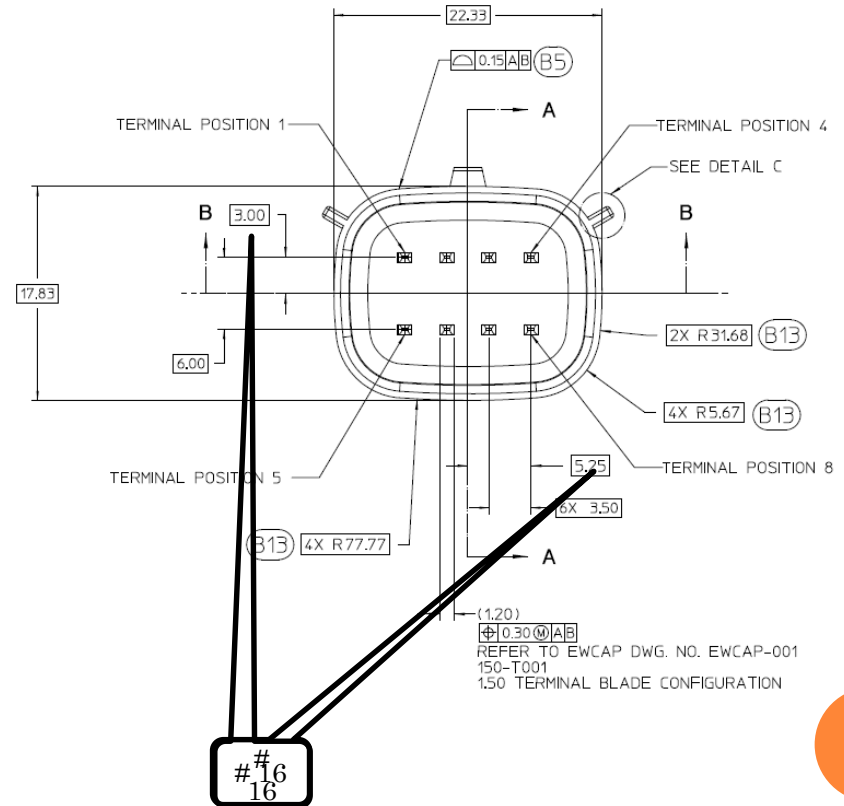
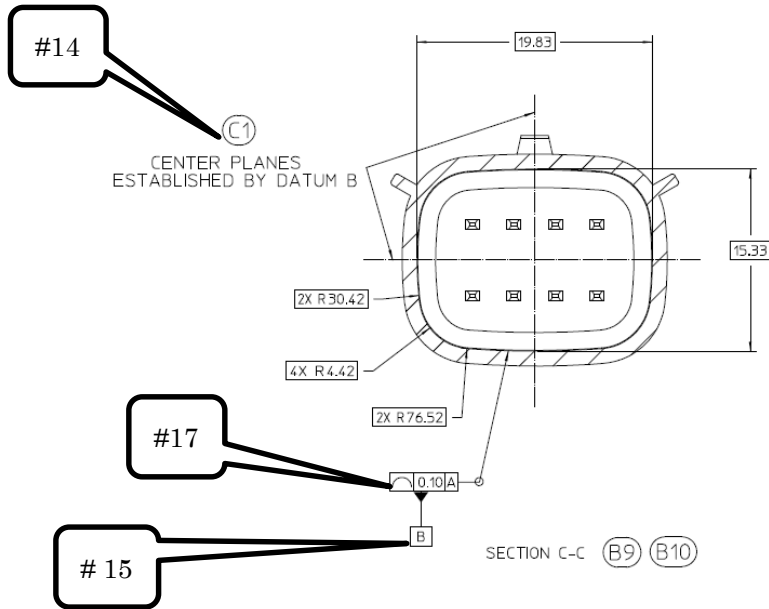

# CONNECTOR FLOOR

- ❑ Req. #18 This note is required to indicate minimum dimension.
- ❑ Req. #19 Show dimension of datum "A" to floor. (May be Minimum or toleranced based on design intent)

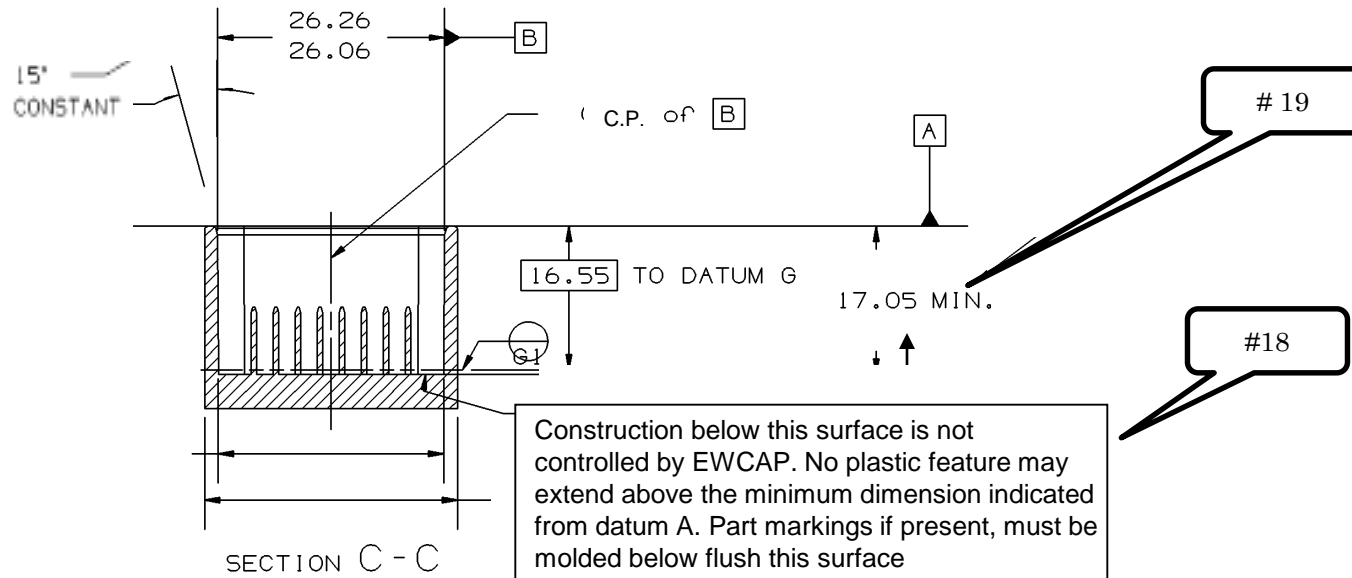

## Connector Floor

This note places the floor of the connector at a minimum dimension from datum A. The floor can float below the minimum dimension. This allows for features (ribs, moats, pyramids, etc.) on the floor of the connector, as needed, without interfering with any mating connector. No plastic including part markings may be above this minimum dimension.

This may be shown as a plane relative to datum A.

# PACKAGING VIEWS

- Req. #20 Show clearance Dimensions

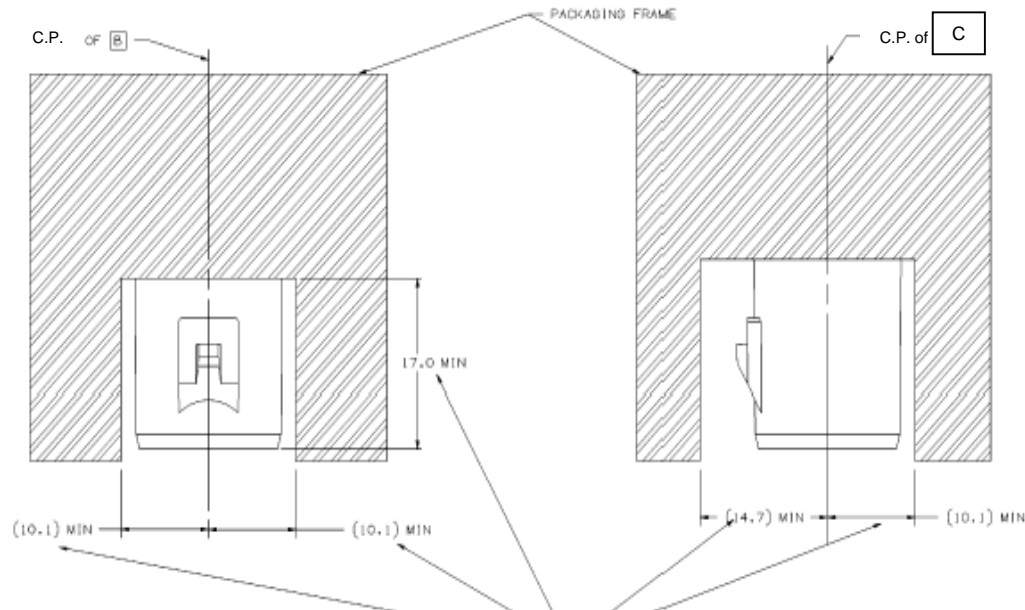

If header is recessed into a pocket, these dimensions represent the minimum clearance required for the mating connector shroud. Note: Additional clearance may be required to allow latch function.



## Packaging View:

The packaging view provides reasonable space for the mating part shroud or other features in the final part design. Dimensions shown are for packaging only. For clarity, the packaging view should be shown in the same orientation as the footprint drawing and show only clearance dimensions. Note: Excessive length between datum "A" and the device housing could interfere with connector mating/un-mating. (See Req#13 for Datum "A" requirement)

# STANDARD NOTES

- Req. #21 All applicable notes shall be shown in a notes field located left of the title block and revision table.

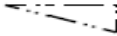
## NOTES:

1. DIMENSIONING AND TOLERANCING PER ASME Y14.5M.
2. 0.25 MAX RADII ON ALL CORNERS SHOWN SHARP.
3. ALL UNSPECIFIED RADII 0.25 MAX.
4. STANDARD COLORS FOR POLARIZATION (SEE CHART IN LEFT LOWER CORNER OF THE DRAWING SHEET)
5. REFER TO "SAE/USCAR 12 CONNECTOR DESIGN CRITERIA" FOR ADDITIONAL REQUIREMENTS.
6. EXCEPT WHERE NOTED, DRAFT ON OUTSIDE SURFACES IS PERMISSIBLE WITHIN TOLERANCE.
7.  SYMBOL INDICATES DRAFT DIRECTION WHEN NECESSARY TO SPECIFY.
8. FOR TERMINAL MATERIAL, DIMENSIONAL, AND COATING REQUIREMENTS SEE EWCAP-001 TERMINAL **XXX-T00X**
9. TO CLAIM USCAR COMPLIANCE, PARTS PRODUCED TO THIS FOOTPRINT DRAWING MUST BE TESTED TO AND MEET THE REQUIREMENTS OF SAE/USCAR 2.
10.  DENOTES DIMENSION THAT MAY BE UTILIZED TO MONITOR PART QUALITY.
11. WHEN USING SILVER PLATED TERMINALS, THE SILVER PLATING MUST STOP A MINIMUM OF 1MM FROM HEADER PLASTIC  
(OTHER NOTES DESCRIBING ADDITIONAL REQUIREMENTS MUST BE SHOWN IN THIS NOTE FIELD).

# BLADE DEPTH

- Req. # 22 Show blade depth dimension from datum "A" and number of blades controlled by this dimension.

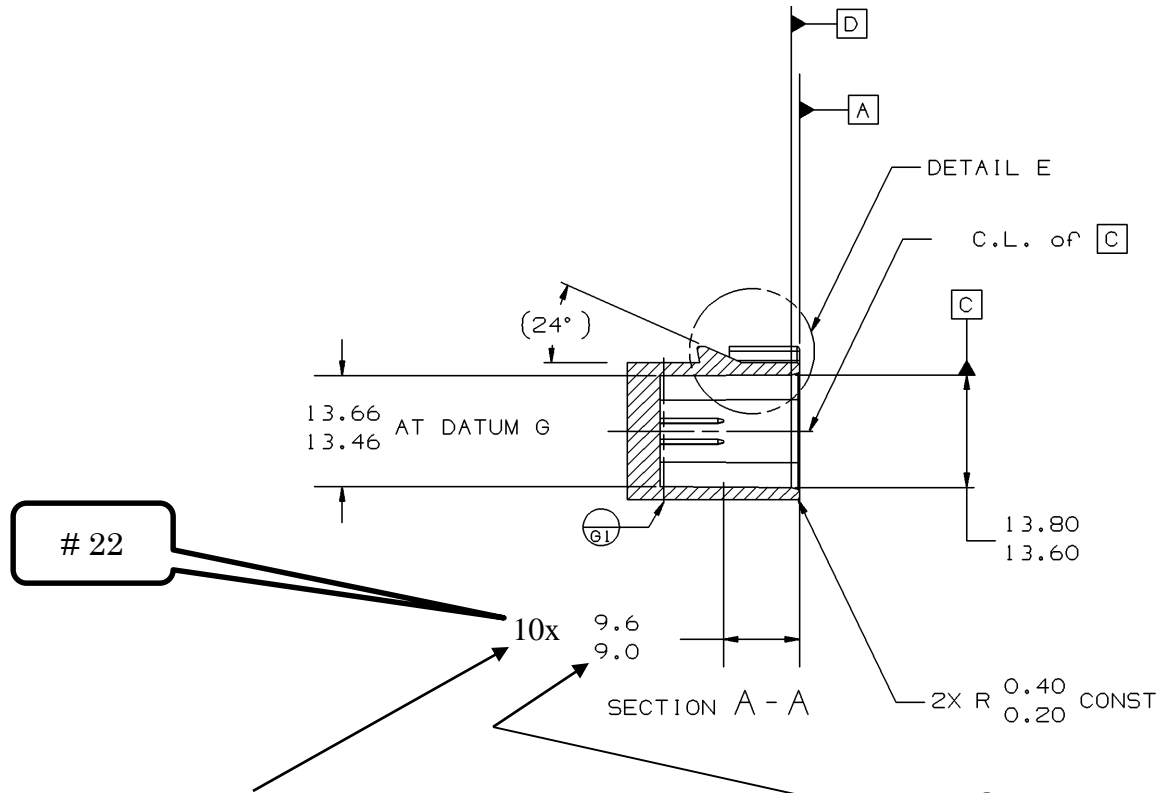

Blade depth:  
Indicate the number of pins and depth dimension from tip to datum "A"

Standard tolerance for blade depth is  $\pm 0.30\text{mm}$ . Any variance from this dimension must be highlighted.

(Blade tip Depth is dimensioned from Datum A)

# CONNECTOR LATCH DETAIL

Req. #27

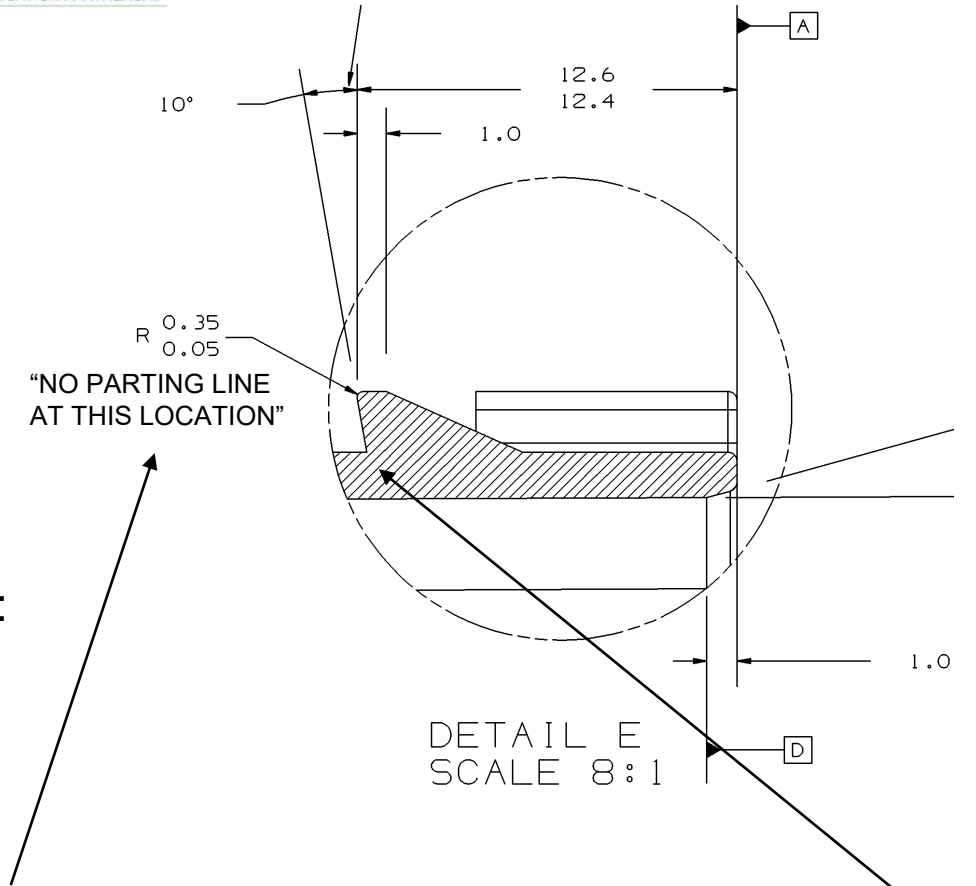

Latch details:

Standard radius for back of external lock (prevents flash and possible lock arm hang-up). No parting line allowed here

Inside radius not required for external lock connectors where there is sufficient plastic back-up

## DEFAULT BLADE TOLERANCES

- Req. #23 Use True Position Tolerance unless approved to deviate from EWCAP.

Default tolerances for all USCAR drawings must follow ASME Y14.5 M-2009, paragraph 1.6.1 for correct decimal dimensioning.

The following default tolerances for terminals are to be used unless approval to deviate is given by the EWCAP projects committee.

Blade	-- True position @ Max Material	
	Base	Tip
0.5mm –	0.1	0.3
0.64mm –	0.15	0.3
1.2mm –	0.15	0.3
1.5mm –	0.2	0.3
2.8mm –	0.1	0.2 Sealed
2.8mm –	0.2	0.3 Un Sealed
6.3mm –	0.2	0.3



## SUPPLIER LOGO

- ❑ Req. #5 Show supplier logo and supplier drawing file number left of the title block.



Supplier's internal file number (if applicable) should also be shown for file tracking purposes (this is not a "part" number)

# BLADE POSITIONAL TOLERANCE

□ Req. #25 Show blade requirements per the EWCAP 001 drawing.

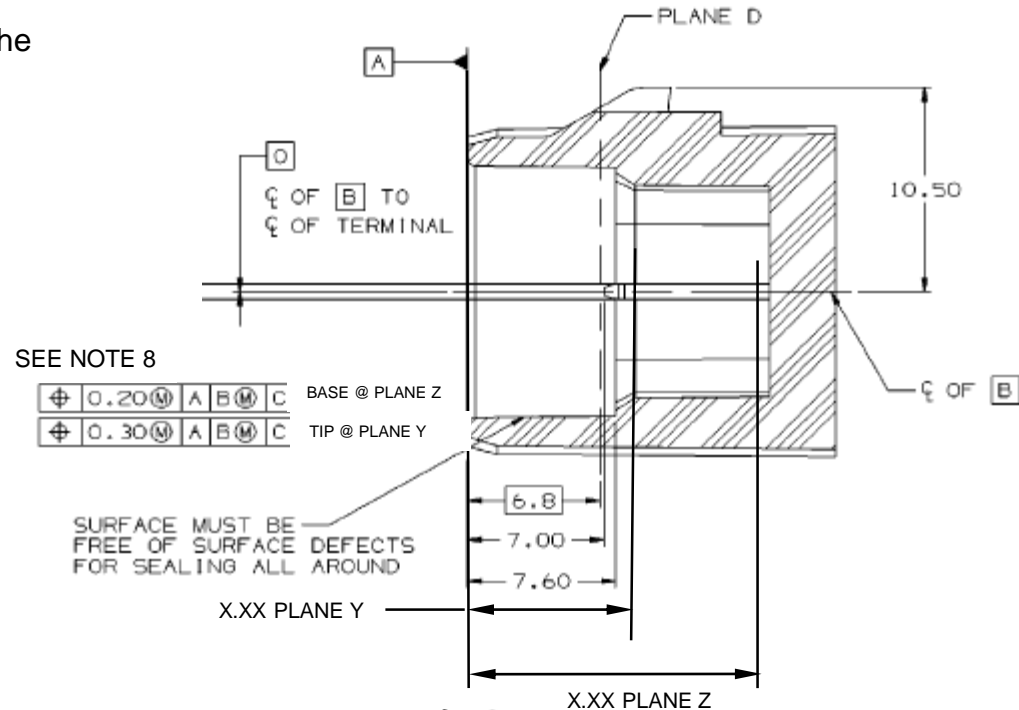

Use this method of showing blade positional tolerance. Do not show the blade dimension even as a reference. This assures that the user refers to the EWCAP 001 blade drawing per the note.

For hybrid applications terminal type (XXX-T-00X) must be identified by location.

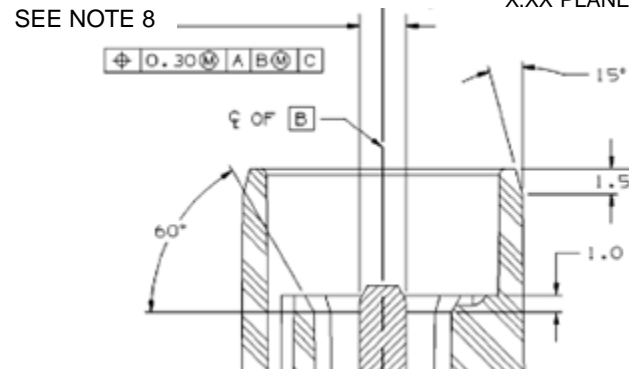

# METHOD FOR SHOWING DRAFT

Req. #24 Show direction of draft if and when necessary.

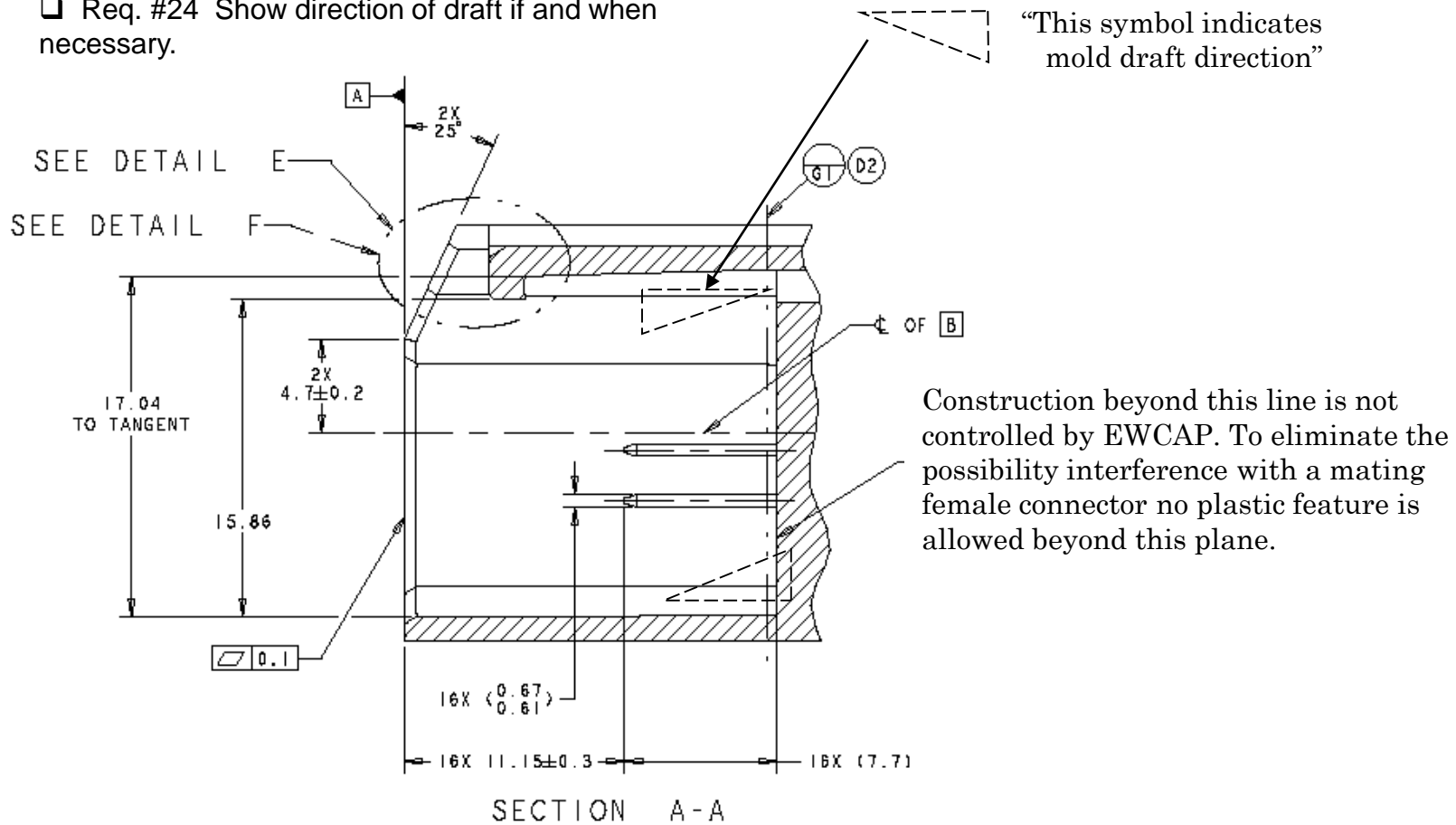

# COLOR/INDEX/PART NUMBER TABLE

❑ Req. #26 Color /index/part number table must be present in the left lower corner of the drawing sheet. Colors specified will be as shown in the drawing table below . Deviations from the color chart will be handled by the OEM release engineer and will not be shown on the USCAR drawing.

## Example Sealed Color Chart

150-S-016-2-A01	A	BLACK
150-S-016-2-B01	B	LT. GRAY
150-S-016-2-C01	C	DK. GRAY
150-S-016-2-D01	D	BLACK
EWCAP PART NUMBER	POLARITY	MATING CONNECTOR COLOR

## Example Unsealed Color Chart

064-U-016-2-A01	A	BLACK
064-U-016-2-B01	B	LT. GRAY
064-U-016-2-C01	C	DK. GRAY
064-U-016-2-D01	D	Black
EWCAP PART NUMBER	POLARITY	MATING CONNECTOR COLOR

# SEALED CONNECTOR SURFACE ID AND CALLOUT

- Req. #33 Proper Identification and specification of maximized Seal Area. Roughness Ra 0.4 Max. Measured with a contact profilometer.

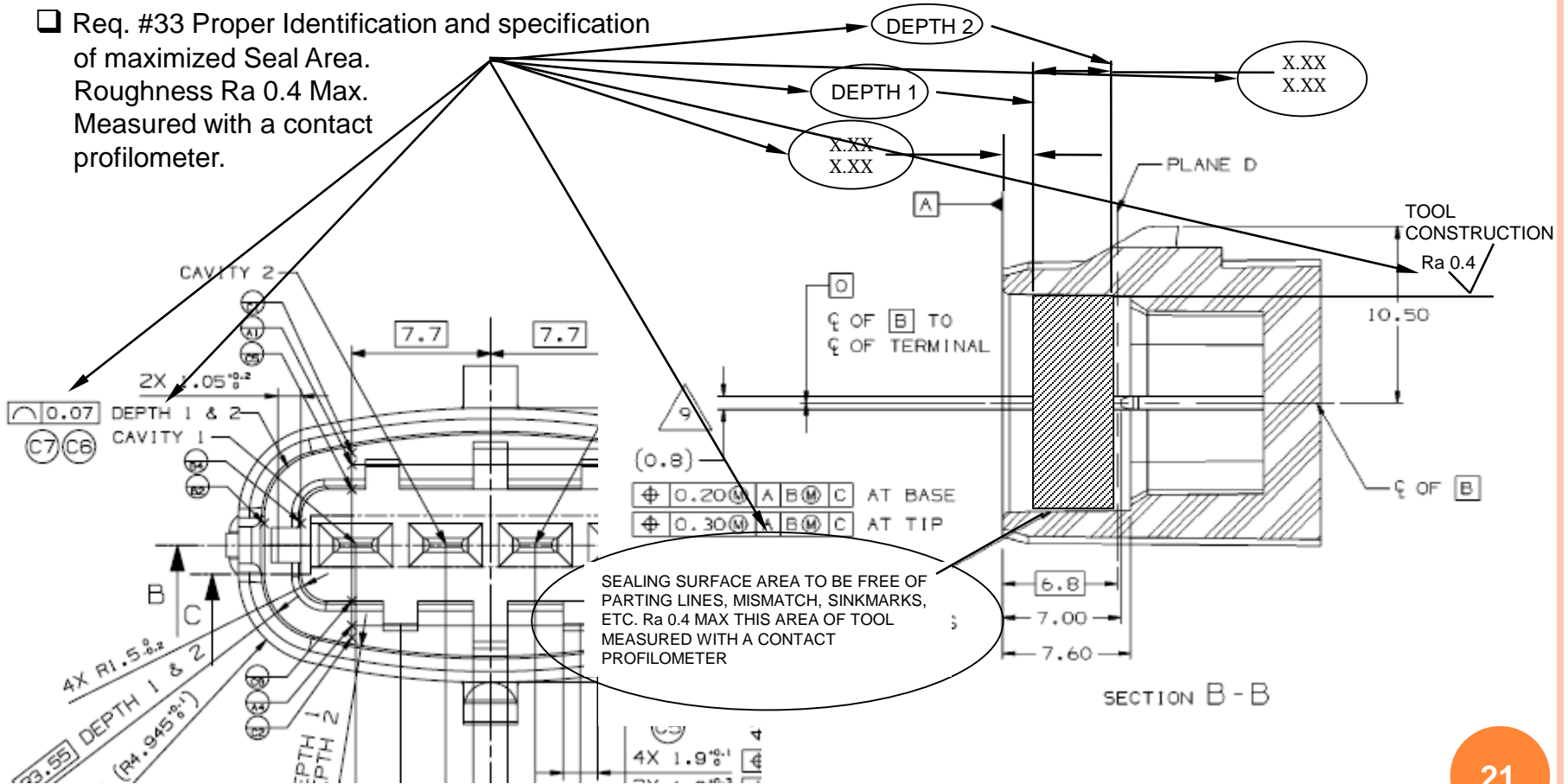



# APPENDIX “B” – NOTICE

□ Req. #8

NOTICE TO BE PUT ON EWCAP DRAWINGS AND ON DRAWINGS THAT COPY PORTIONS OF A DRAWING RELEASED BY EWCAP. (Note that related DRAWING NOT GENERATED BY EWCAP MUST STILL CONTAIN THIS NOTICE)

## Standard Notice

This drawing, or portions of it, are controlled by the Electrical Wiring Components Application Partnership (EWCAP) a subgroup of the United States Council for Automotive Research LLC (USCAR LLC).

USCAR is an LLC consisting of members from FCA US LLC, Ford Motor Company and GM Company.

Any change to a EWCAP controlled portion of this drawing, including a revision record change must be approved, in writing, by the responsible EWCAP representative from each USCAR member company. Each EWCAP representative authorized to sign for his or her member company is responsible for obtaining all necessary approvals within that company prior to signing for the approval of the change.

EWCAP expressly prohibits any party from changing either any EWCAP controlled portion of this drawing or any associated tooling before receiving approval, signed by the authorized representatives, of the USCAR member companies. Reference to the signed change notice must be entered in the drawing control column.

# Appendix C: Additional deliverables with drawing submission

□ Req. #31

- Other than the drawing, the following must be submitted as part of a complete drawing package.
  1. Identification of whether this part is tooled or design-only. Submit the following information to the EWCAP release engineer: Supplier part number, OEM part number (list all that apply), color, and polarizations available.
  2. 2D C or A2 size drawing as a (.dxf) and Acrobat (.pdf) file. Drawing border = 406 x 534. Use multiple sheets if additional drawing space is required.
  3. Provide native CAD model. This CAD information will be considered confidential and will be used by USCAR should revisions be necessary. This information not be shared with suppliers.
  4. 3D data (STEP format) for footprint modeling by users. One model for each keying detail.



# LEGAL NOTICE

☐ Req. #31

**EWCAP LEGAL NOTICE  
(REQUIRED ON ALL EWCAP DRAWINGS)  
REVISION 7-18-2019**

## NOTICE

EWCAP HAS SELECTED COMMON DIMENSIONS FOR THE CONNECTOR(S) DEPICTED AND DESCRIBED HEREIN (LISTED BELOW). FURTHER, EWCAP HAS SELECTED FOR PUBLICATION THIS DRAWING (AND ITS COMPANION ELECTRONIC MODEL) PREPARED BY ----- COMPANY NAME ---- AS REPRESENTATIVE OF A CONNECTOR HAVING THESE DIMENSIONS. IN EXCHANGE FOR THE CONSIDERATION OF THE SELECTION OF THIS DRAWING FOR PUBLICATION (INCLUDING POSTING ON EWCAP'S WEB SITE) AND OTHER GOOD AND VALUABLE CONSIDERATION FLOWING FROM THIS SELECTION, ---- COMPANY NAME ---- HEREBY AGREES ON BEHALF OF ITSELF AND ITS SUCCESSORS AND ASSIGNS, WITH RESPECT TO ANY COPYRIGHTS IT MAY HAVE IN THIS DRAWING AS WELL AS ANY PATENT RIGHTS IT MAY HAVE IN THE CONNECTOR ILLUSTRATED IN THIS DRAWING, NOT TO ENFORCE SUCH COPYRIGHTS AND PATENTS AGAINST ANY PERSON OR ENTITY ON ACCOUNT OF THEIR ACTIVITIES TO MAKE, HAVE MADE, USE AND SELL THE CONNECTOR ILLUSTRATED IN THIS DRAWING FOR VEHICULAR APPLICATIONS. THE TERM "CONNECTOR" AS USED IN THIS PARAGRAPH IS LIMITED SOLELY TO THE STRUCTURE SPECIFICALLY ILLUSTRATED IN THIS DRAWING. NO WARRANTIES OR INDEMNITIES OF ANY KIND ARE MADE OR IMPLIED BY ---- COMPANY NAME ---- OR EWCAP. IN PARTICULAR THERE ARE NO EXPRESS OR IMPLIED WARRANTIES OF FITNESS FOR A PARTICULAR PURPOSE, MERCHANTABILITY, NON-INFRINGEMENT OR ANY OTHER WARRANTY OF ANY KIND. IN ADDITION, THERE ARE NO EXPRESS OR IMPLIED WARRANTIES OR INDEMNITIES OF ANY KIND RELATING TO THIRD PARTY CLAIMS ARISING UNDER THE INTELLECTUAL PROPERTY LAWS OF ANY COUNTRY. ANYONE USING THE INFORMATION IN THIS DRAWING DOES SO AT THEIR OWN RISK.

APPLICABLE EWCAP DRAWING NUMBERS:

\_\_\_\_\_  
\_\_\_\_\_

# APPENDIX E: CHECKLIST TEMPLATE

Checklist Summary    Part Number \_\_\_\_\_    Rev Level \_\_\_\_\_    Date Checked \_\_\_\_\_

Requirement #	Requirement Description	Compliant	Comments
1	Part Number compliance		
2	Data format and related info per Appendix C		
3	GD&T per ASME Y14.5M 2009		
4	Multiple C (A2) size sheets (420 x 594)mm		
5	Supplier Name/ Logo and Drawing File number		
6	Compliance with view placement		
7	EWCAP Title block compliance		
8	EWCAP disclosure notice per latest release		
9	Deviation approval by projects committee		
10	Fully detailed foot print can be tooled from the drawing		
11	Gauging requirements are listed in the notes.		
12	Blade location and labeling.		
13	Datum A is Connector face		
14	Datum B is Primary shroud length		
15	Datum C is Secondary shroud length		
16	Confirm terminal spacing is dimensioned to datum B and C		
17	Connector defined with basic dimensions to allow Profile of a surface tolerance		
18	Disclaimer note stating we don't control stuff below given dimension		
19	Datum A to Connector floor dimensioned		
20	Packaging views are present and located per the requirements		
21	Drawing Notes are present and at the latest level.		
22	Blade depth, Datum A to blade tip is appropriately dimensioned		
23	Verify Blade Positional Tolerance		
24	Draft is defined if / when necessary and designated properly		
25	Verify Blade size is not referenced or detailed and note is specified concerning EWCAP 001 Blade drawing including the correct terminal reference		
26	Is Color / Polarization / Part number table on the drawing in lower left corner.		
27	Shark fin defined correctly with correct size		
28	Drafting font type and size		
29	Drafting line Type and Weight		
30	Rev Column and Balloons		
31	Legal Notice is correctly completed and added as last page of the drawing		
32	Identify thin sections & poor tool conditions make sure addressed on the print		
33	For sealed connectors proper identification of seal area with notes		