

INDEX

PAGE TITLE

PAGE

TITLE / REVISION BLOCK, NOTES, PACKAGING, P/N CHART, POLARIZATION	1
064-T-00X, 120-T-00X	2
150-T-00X, 280-T-00X	3

NOTICE

THIS DRAWING, OR PORTIONS OF IT, ARE CONTROLLED BY THE ELECTRICAL WIRING COMPONENTS APPLICATION PARTNERSHIP (EWCAP), A SUBGROUP OF THE UNITED STATES CONSORTIUM FOR AUTOMOTIVE RESEARCH, LLC (USCAR). USCAR IS A PARTNERSHIP BETWEEN CHRYSLER GROUP LLC, FORD MOTOR COMPANY AND GENERAL MOTORS CORPORATION. ANY CHANGES TO A EWCAP CONTROLLED PORTION OF THIS DRAWING, INCLUDING A "RECORD CHANGE" MUST BE APPROVED IN WRITING BY THE RESPONSIBLE EWCAP MEMBER FROM EACH USCAR COMPANY. EACH EWCAP MEMBER AUTHORIZED TO SIGN FOR HIS OR HER COMPANY IS RESPONSIBLE FOR OBTAINING ALL NECESSARY APPROVALS WITHIN THAT COMPANY PRIOR SIGNING FOR APPROVAL OF THE CHANGE. EWCAP EXPRESSLY PROHIBITS ANY PARTY FROM CHANGING EITHER ANY EWCAP CONTROLLED PORTION OF THIS DRAWING OR ANY ASSOCIATED TOOLING BEFORE RECEIVING AN APPROVAL SIGNED BY AN AUTHORIZED REPRESENTATIVE FROM EACH EWCAP PARTNER. REFERENCE TO THE SIGNED APPROVAL FROM MUST BE ENTERED IN THIS DRAWING'S CONTROL COLUMN.

NOTES: UNLESS OTHERWISE SPECIFIED

- EWCAP-004 IS A GUIDELINE FOR ANTI-TRACKING GEOMETRY (CREEPAGE) ONLY. DEPENDING ON APPLICATION AND REQUIREMENTS, CHANGES MAY BE REQUIRED.
  - DIMENSIONS ESTABLISHED TO BE COMPLIANT TO UL 840, TABLE 9.1, ≤300 VOLTS PEAK TO PEAK. CREEPAGE DISTANCE MUST BE RE-CALCULATED FOR VOLTAGE LEVELS >300 VOLTS PEAK TO PEAK.
  - 5.0mm TOTAL PATH DISTANCE AT WORST CASE IS REQUIRED TO BE COMPLIANT. SUPPLIER MUST WORK WITH THEIR CUSTOMER TO ACHIEVE THE 5.0mm MINIMUM VALUE.
  - DIMENSIONS SHOWN ON EWCAP-004 ARE NOMINAL. TOLERANCES ARE NOT SHOWN INTENTIONALLY SINCE CAPABILITY WILL VARY WITH PROCESS TYPE.
  - DIMENSION OF GROOVE MUST BE COMPLIANT TO UL 840 SECTION 10.2.
  - THE MINIMUM PITCH IS SHOWN. FOR LARGER PITCHES, THE FLAT DIMENSIONS IN THE BOTTOM OF THE CONNECTOR PERPENDICULAR TO THE BLADES CAN BE INCREASED AS NEEDED.
- THE OPEN AIR CLEARANCE REQUIREMENTS MUST BE CALCULATED BY THE RESPOSIBLE PARTY(S) AND SPECIAL ATTENTION MUST BE GIVEN TO ENSURE FUNCTIONALITY OF THE SYSTEM.
- ALL ANGLES SHALL REMAIN THE SAME.
  - REFERENCE DOCUMENT:  
UL 840 THRID EDITION, 2005
  - REFERENCE INFORMATION:  
POLLUTION DEGREE: 3  
MATERIAL GROUP: IIIA / IIIB  
OVERVOLTAGE CATERGORY: II  
RATED IMPULSE WITHSTAND VOLTAGE PEAK: 2,500 V  
ALTITUDE: 2,000 m

POLARIZATION VIEWS

EWCAP PART NUMBER	INDEX	COLOR

-	A	NEW	07-20-2012	WB	SV
CHANGE NUMBER	LET	REVISION RECORD	DATE	DWN	CHK
TOLERANCES (UNLESS OTHERWISE SPECIFIED)			THIRD ANGLE PROJECTION		
DIMENSIONS ARE IN MILLIMETERS					



SCALE	DRAWN BY	CHECKED BY	DATE
2/1	W. BIENIEK	S. VOGT	07-20-2012
TITLE ANTI-TRACKING GEOMETRY - 064, 120, 150, AND 280			
SHEET	DRAWING NUMBER	SIZE	REVISION LEVEL
1 OF 3	EWCAP-004	C	A
DO NOT SCALE COMPUTER AIDED DRAWING			



VERSION A:  
DEVICE

VERSION B:  
INLINE CONNECTOR / FRONT TPA / DEVICE

MIN. PITCH 2.54mm

CREEPAGE: 5.27  
CLEARANCE: 1.90

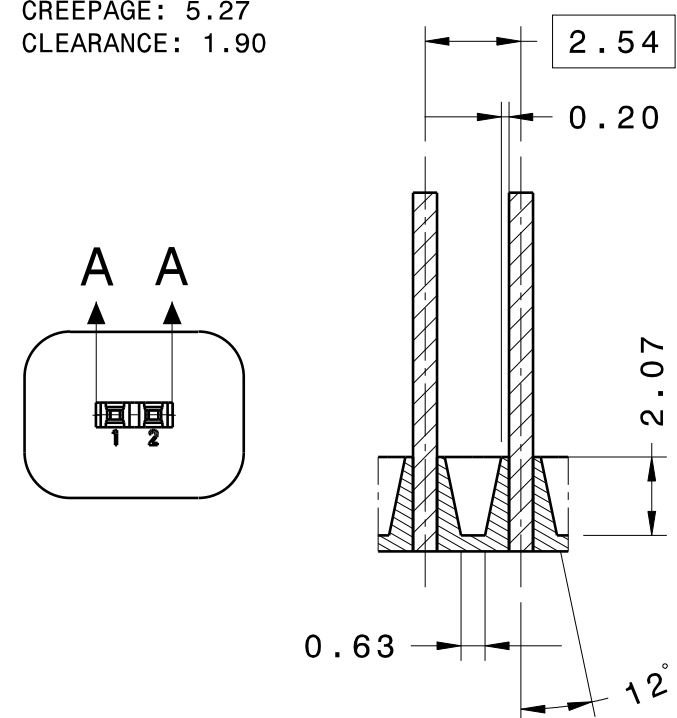

SEC. A-A (5/1)

064-T-001

MIN. PITCH 3.50mm

CREEPAGE: 5.35  
CLEARANCE: 2.86

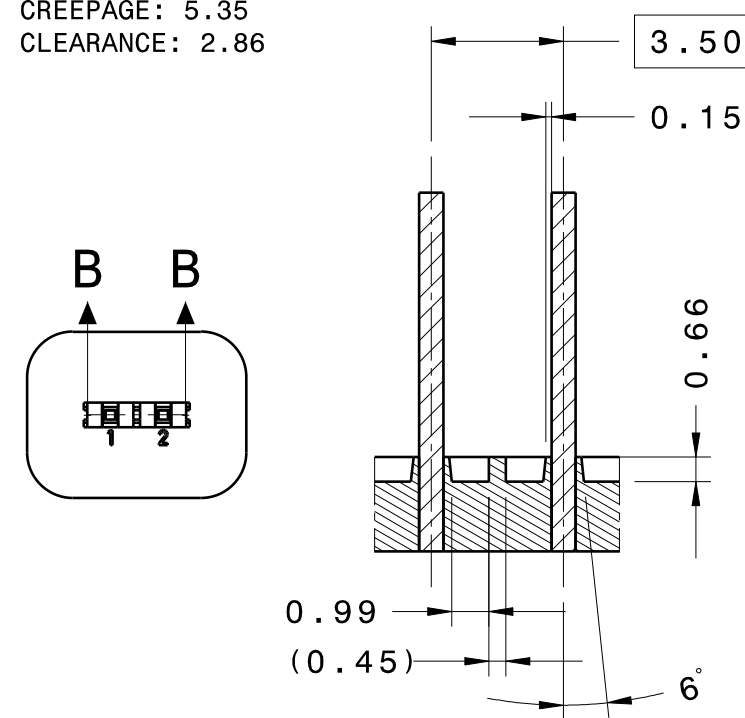

SEC. B-B (5/1)

064-T-002

MIN. PITCH 2.50mm

CREEPAGE: 5.43  
CLEARANCE: 1.30

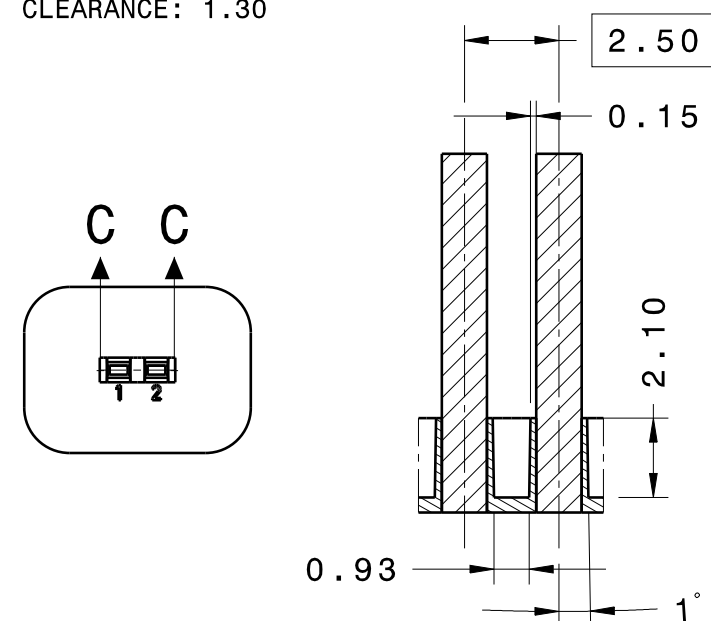

SEC. C-C (5/1)

120-T-001

MIN. PITCH 4.00mm

CREEPAGE: 5.25  
CLEARANCE: 2.80

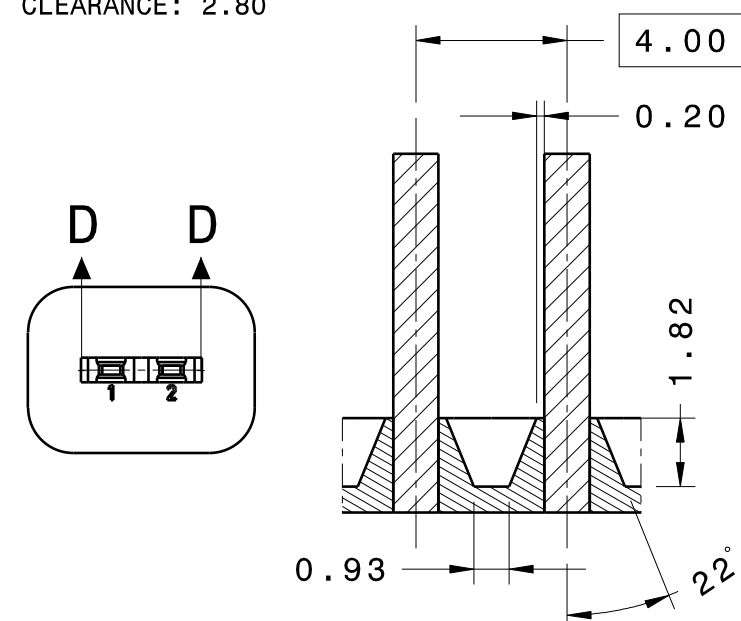

SEC. D-D (5/1)

120-T-002

MIN. PITCH 4.00mm

CREEPAGE: 5.22  
CLEARANCE: 2.80

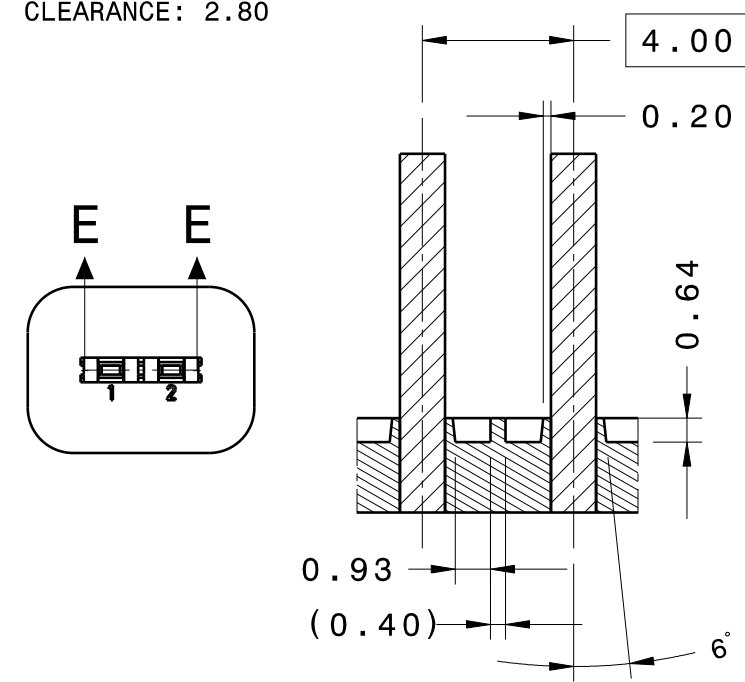

SEC. E-E (5/1)

120-T-003

MIN. PITCH 4.00mm

CREEPAGE: 5.22  
CLEARANCE: 2.80

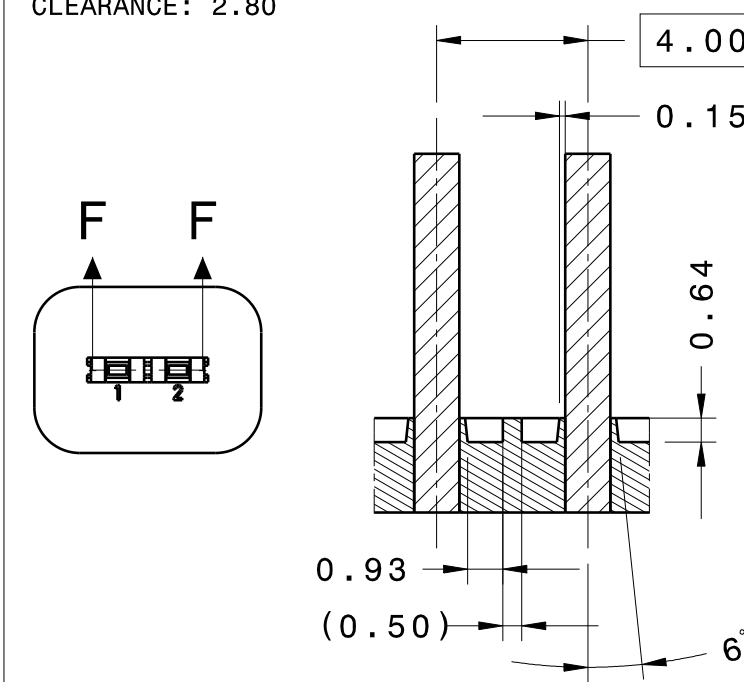

SEC. F-F (5/1)

120-T-004

TOLERANCES (UNLESS OTHERWISE SPECIFIED)		THIRD ANGLE PROJECTION	
DIMENSIONS ARE IN MILLIMETERS			

EWCAP

SCALE 2/1	DRAWN BY W. BIENIEK	CHECKED BY S. VOGT	DATE 07-20-2012
TITLE ANTI-TRACKING GEOMETRY - 064, 120, 150, AND 280			
SHEET 2 OF 3	DRAWING NUMBER EWCAP-004	SIZE C	DO NOT SCALE COMPUTER AIDED DRAWING
			REVISION LEVEL A

KOSTAL  
Kontakt Systeme, Inc.

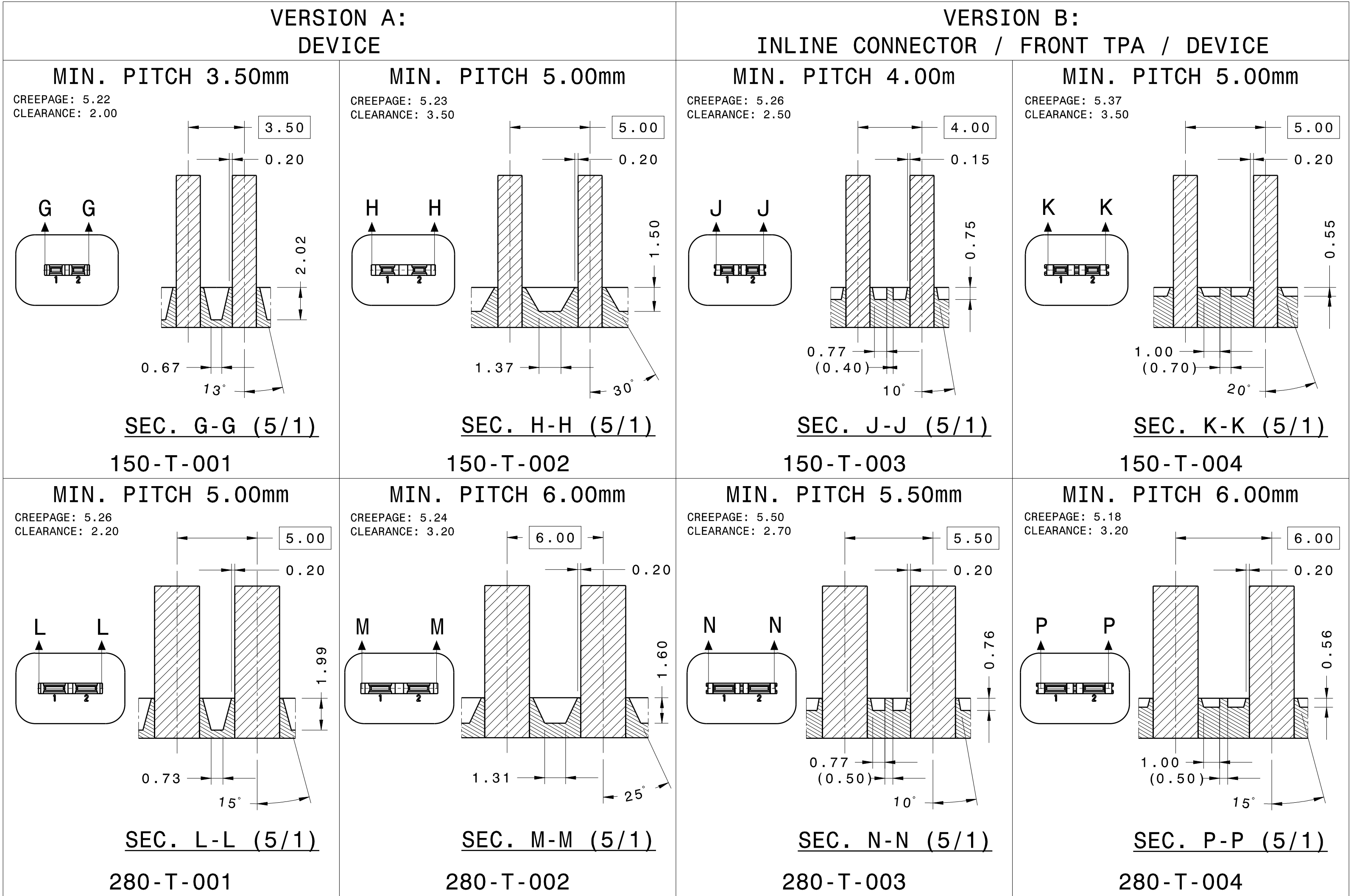

TOLERANCES (UNLESS OTHERWISE SPECIFIED)		THIRD ANGLE PROJECTION	
DIMENSIONS ARE IN MILLIMETERS			
<b>EWCAP</b>			
SCALE 2/1	DRAWN BY W. BIENIEK	CHECKED BY S. VOGT	DATE 07-20-2012
TITLE ANTI-TRACKING GEOMETRY - 064, 120, 150, AND 280			
SHEET 3 OF 3	DRAWING NUMBER EWCAP-004	SIZE C	DO NOT SCALE COMPUTER AIDED DRAWING REVISION LEVEL A

