

ISOMETRIC VIEW
SCALE 1:1

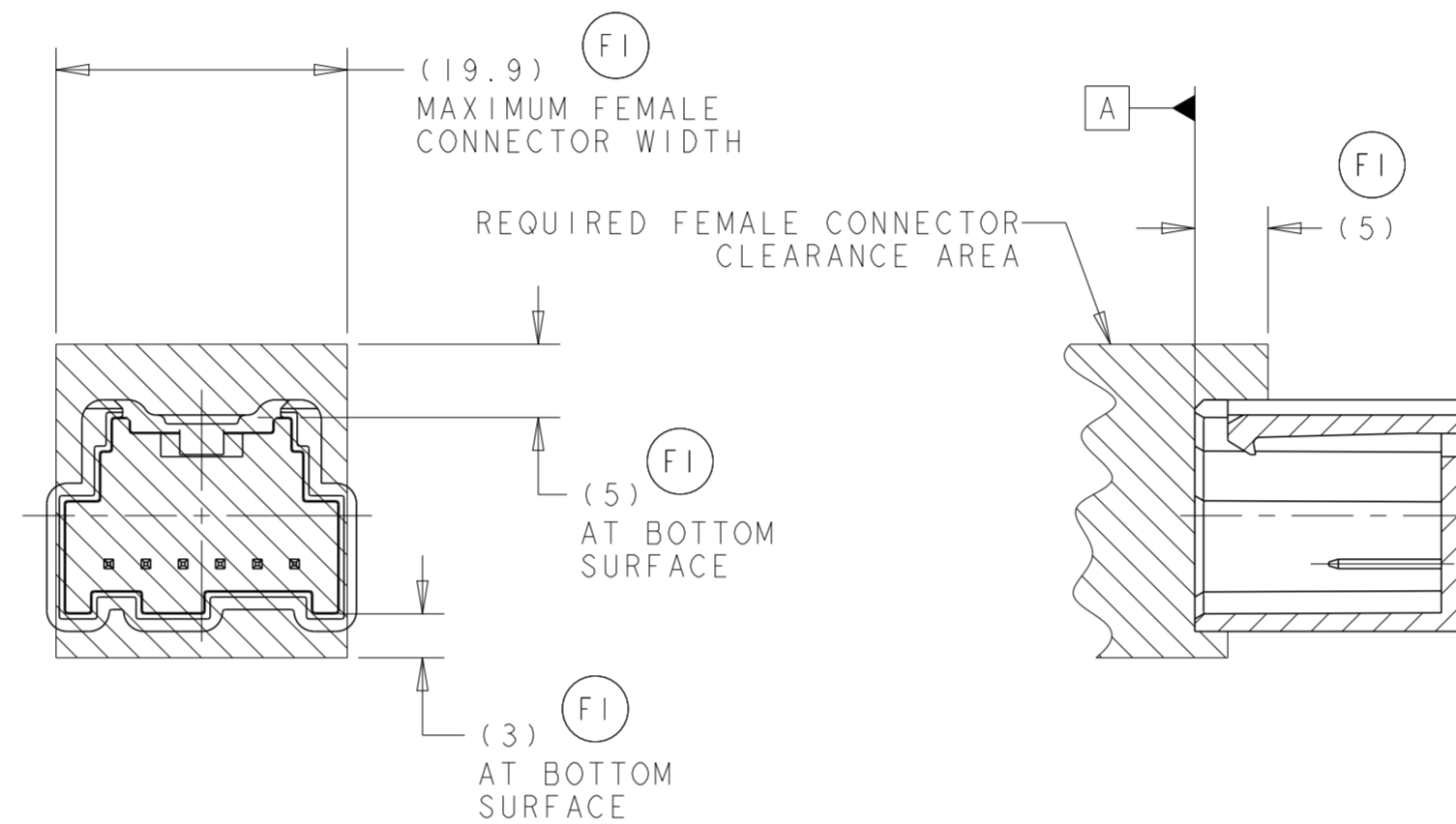

NOTE(S):

1. ALL KEY OPTIONS MUST BE FEASIBLE IN TOOL.
2. UNLESS OTHERWISE SPECIFIED, ALL BLENDS = 0.20.
3. UNLESS OTHERWISE SPECIFIED, 0.25° MAXIMUM DRAFT ANGLE STARTING AT PLANE G.
4. CONNECTOR OUTSIDE CONFIGURATION AND DIMENSIONS NOT DEFINED EXCEPT WHERE NOTED. RECOMMENDED WALL THICKNESS 1.2 TYPICAL.
5. STANDARD COLORS - DEVIATION REQUIRES APPROVAL OF AUTHORIZED PERSON.
6. REFER TO DRAWING EWCAP-001, DETAIL 064-T001 FOR CONTACT PIN TIP INFORMATION.
7. NOTE DELETED.
8. NOTE DELETED.
9. THIS GEOMETRY IS OPTIONAL.
10. DIMENSIONING AND TOLERANCING PER ASME Y14.5M-1994.
11. REVERSE DRAFT PERMISSIBLE ON LATCH DETAILS.
12. SYMBOL INDICATES MOLD DRAFT DIRECTION.

NOTICE

THIS DRAWING, OR PORTIONS OF IT ARE CONTROLLED BY THE ELECTRICAL WIRING COMPONENTS APPLICATION PARTNERSHIP (EWCAP), A SUBGROUP OF THE UNITED STATES COUNCIL FOR AUTOMOTIVE RESEARCH LLC (USCAR LLC).

USCAR IS A LLC CONSISTING OF MEMBERS FROM FCA US LLC, FORD MOTOR COMPANY, AND GM CORPORATION.

ANY CHANGE TO A EWCAP CONTROLLED PORTION OF THIS DRAWING, INCLUDING A REVISION RECORD CHANGE MUST BE APPROVED, IN WRITING, BY THE RESPONSIBLE EWCAP REPRESENTATIVE FROM EACH USCAR MEMBER COMPANY. EACH EWCAP REPRESENTATIVE AUTHORIZED TO SIGN FOR HIS OR HER MEMBER COMPANY IS RESPONSIBLE FOR OBTAINING ALL NECESSARY APPROVALS WITHIN THAT COMPANY PRIOR TO SIGNING FOR THE APPROVAL OF THE CHANGE.

EWCAP EXPRESSLY PROHIBITS ANY PARTY FROM CHANGING EITHER ANY EWCAP CONTROLLED PORTION OF THIS DRAWING OR ANY ASSOCIATED TOOLING BEFORE RECEIVING APPROVAL, SIGNED BY THE AUTHORIZED REPRESENTATIVES, OF THE USCAR MEMBER COMPANIES. REFERENCE TO THE SIGNED CHANGE NOTICE MUST BE ENTERED IN THE DRAWING CONTROL COLUMN.

0143	H1	REMOVED NOTES 7 AND 8 AND DETAIL E	07-13-17	RGV	CJS
0133	G1	ADDED PARALLELISM CONTROL	01-09-17	DLD	CJS
0047	F14	CHANGED DATUM G TO PLANE G AND DELETED ALL RELATED DATUM TARGET SYMBOLS	10/22/04	BEC	JG
	F13	ADDED ±3° 2 PLACES IN DETAIL E AND DETAIL F			
	F12	REMOVED FLATNESS INDICATOR ON SECTION A			
	F11	ADDED DRAFT DIRECTION INDICATORS TO SEC. A & C. ADDED NOTE 12			
	F10	ADDED NOTE 11.			
	F9	ADDED "TYP" TO 1.5±0.1 DIM			
	F8	ADDED "2X" TO 13.43 DIM			
	F7	ADDED "CONNECTOR OUTSIDE CONFIGURATION AND DIMENSIONS NOT DEFINED EXCEPT WHERE NOTED" TO NOTE 4.			
	F6	CHANGED NOTE 2 FROM "0.2" TO "0.20"			
	F5	CHANGED NOTE 3, WAS "STARTING AT DATUM -D- "			
	F4	ADDED "2X" TO DETAIL G			
F3	ADDED NOTCH TO TOP VIEW AND ADDED 5±0.25 FROM FRONT TO TOP VIEW				
F2	CHANGED FEATURE CONTROL FRAMES ON PIN POSITION				
F1	CHANGED DIMENSIONS IN PACKAGING VIEW TO REFERENCE				
0032	E10	ADDED NOTE #10	11/18/03	MFF	JG
	E9	CHANGED BLOCK TOLERANCE FOR ANGLES FROM ±0° 30' TO ±2°			
	E8	REMOVED ±2°			
	E7	ADDED MISSING DIMENSIONS AND REMOVED SEE DETAIL E FOR MISSING DIMENSIONS			
	E6	MOVED FROM SECTION A-A			
	E5	CHANGED NOTE 3 FROM 0.25 DEGREE DRAFT SHOWN, STARTING AT DTM_D:12 CHANGED NOTE 4 FROM WALL THICKNESS 1.2 TYPICAL.			
	E4	13.68 +0.13/-0.08 AND 13.43 +0.13/-0.08 WAS 13.68±0.08 AND 13.43±0.08			
	E3	ADDED 16.35 , 13.46 MIN, 13.21 MIN, AND DTM_A:24			
	E2	ADDED DATUM G1 TO SECTION A-A, SECTION B-B, AND SECTION C-C			
	E1	ADDED DETAIL G AND NOTE #9			
0022	D2	ADDED TERMINAL PIN NUMBERS	07/10/03	MFF	JG
	D1	30° ±2° WAS 30.2° ±0.2°			
0020	C	RELEASED	05/01/03	MFF	JG
0013	B	RELEASED	02/17/03	MFF	JG
	A	RELEASED			
CHANGE SERIAL NUMBER	LET	REVISION RECORD	DATE	DWN	CHK
TOLERANCES (UNLESS OTHERWISE SPECIFIED)			THIRD ANGLE PROJECTION		
DIMENSIONS ARE IN MILLIMETERS					
ANGLES ± 2°					
X.X ± 0.25			X.XX ± 0.13		

E9

064-U-006-1-A02	A	BLACK
064-U-006-1-B02	B	GRAY
064-U-006-1-C02	C	BROWN
064-U-006-1-D02	D	GREEN
064-U-006-1-E02	E	DARK BLUE
064-U-006-1-F02	F	NATURAL/WHITE
EWCAP P/N	POLARITY	MATING CONNECTOR COLOR



USCAR-EWCAP			
SCALE 2:1	DRAWN BY N. SOOCH	CHECKED BY B. HULPIAU	DATE 05-17-01
TITLE 1 X 6 UNSEALED INTERFACE 0.64mm CONNECTORS			
SHEET 1 OF 2	DRAWING NUMBER 064-U-006-1-Z02	SIZE A2	DO NOT SCALE DRAWING COMPUTER AIDED DRAWING REVISION LEVEL H

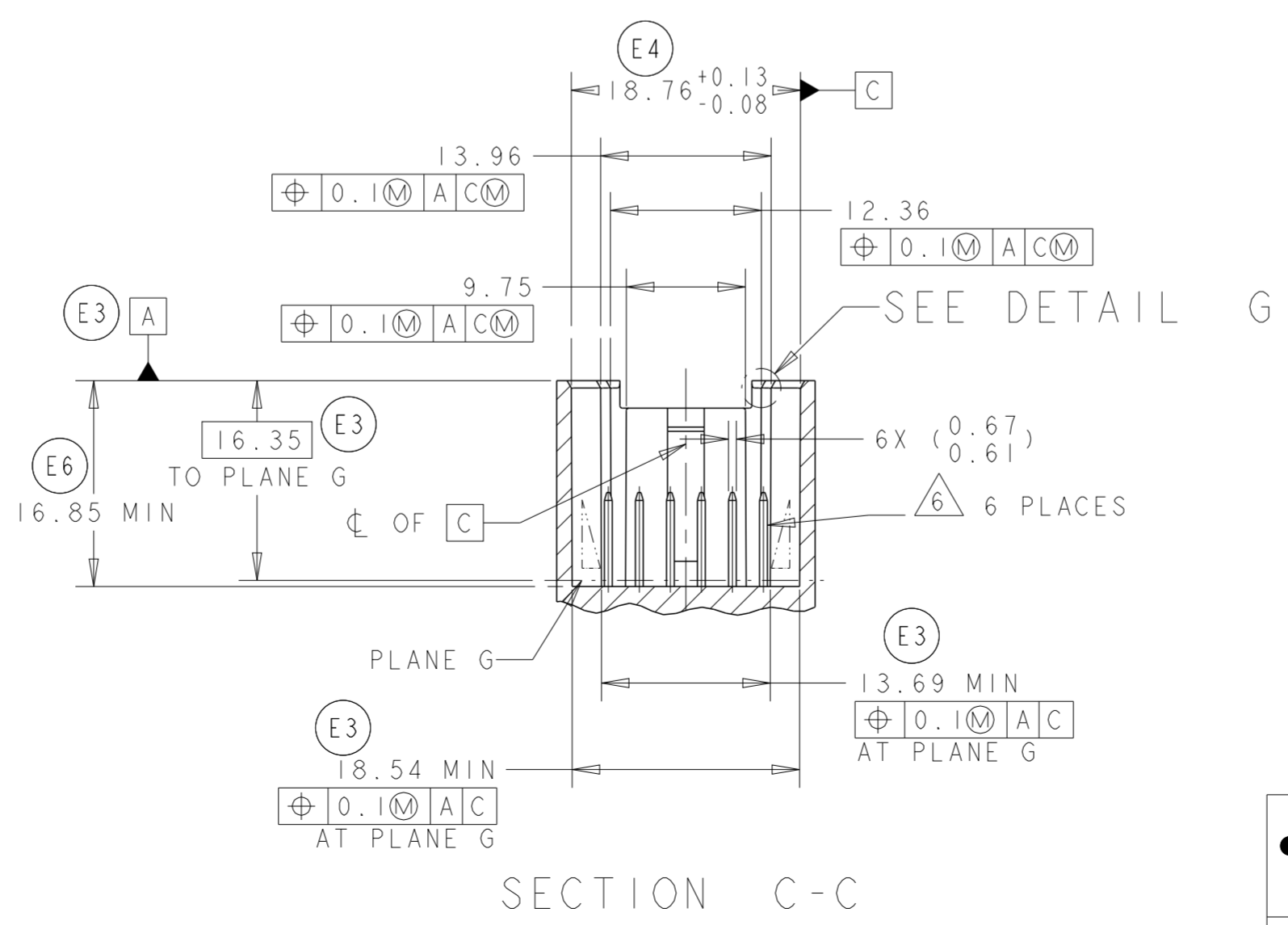
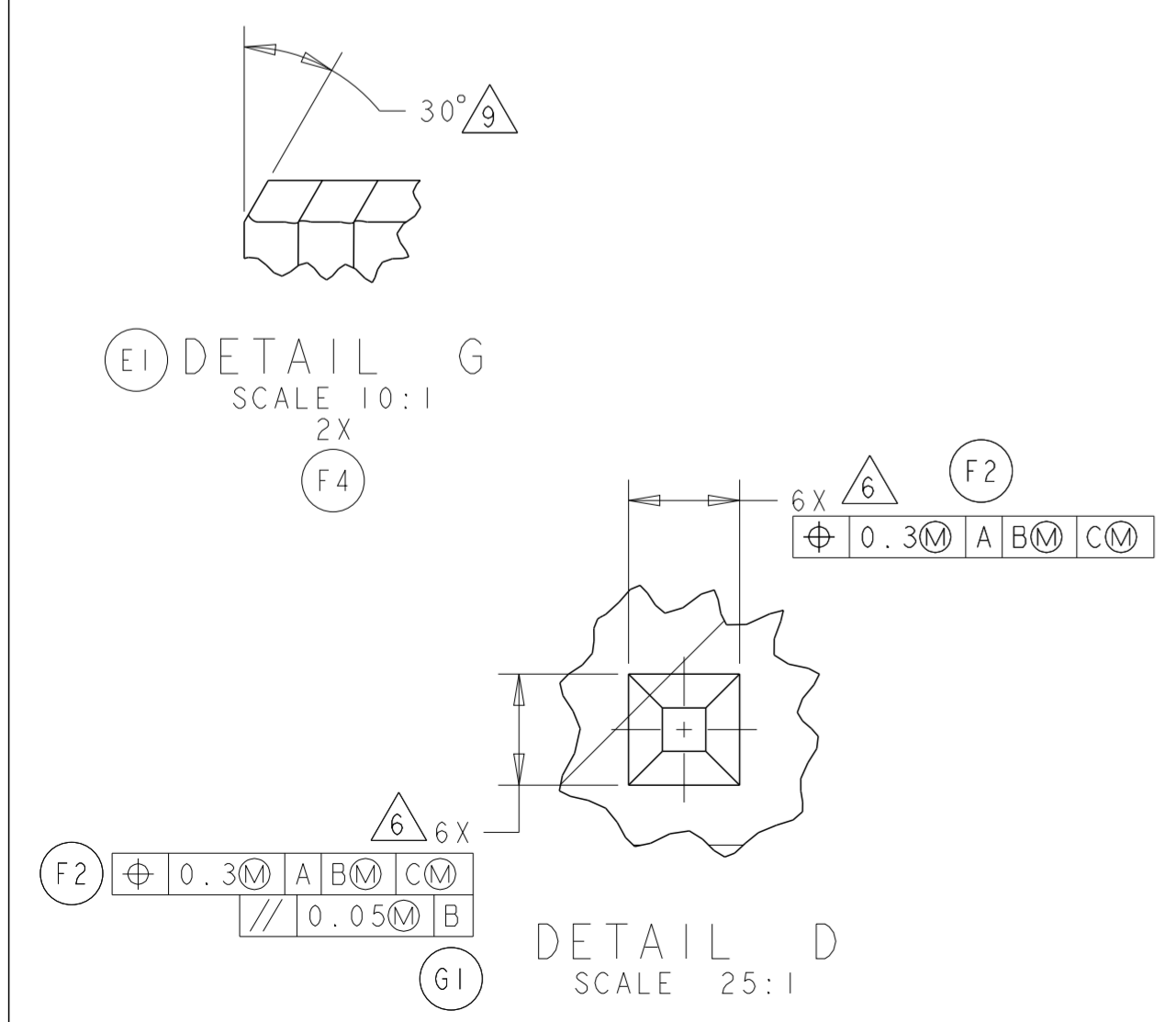
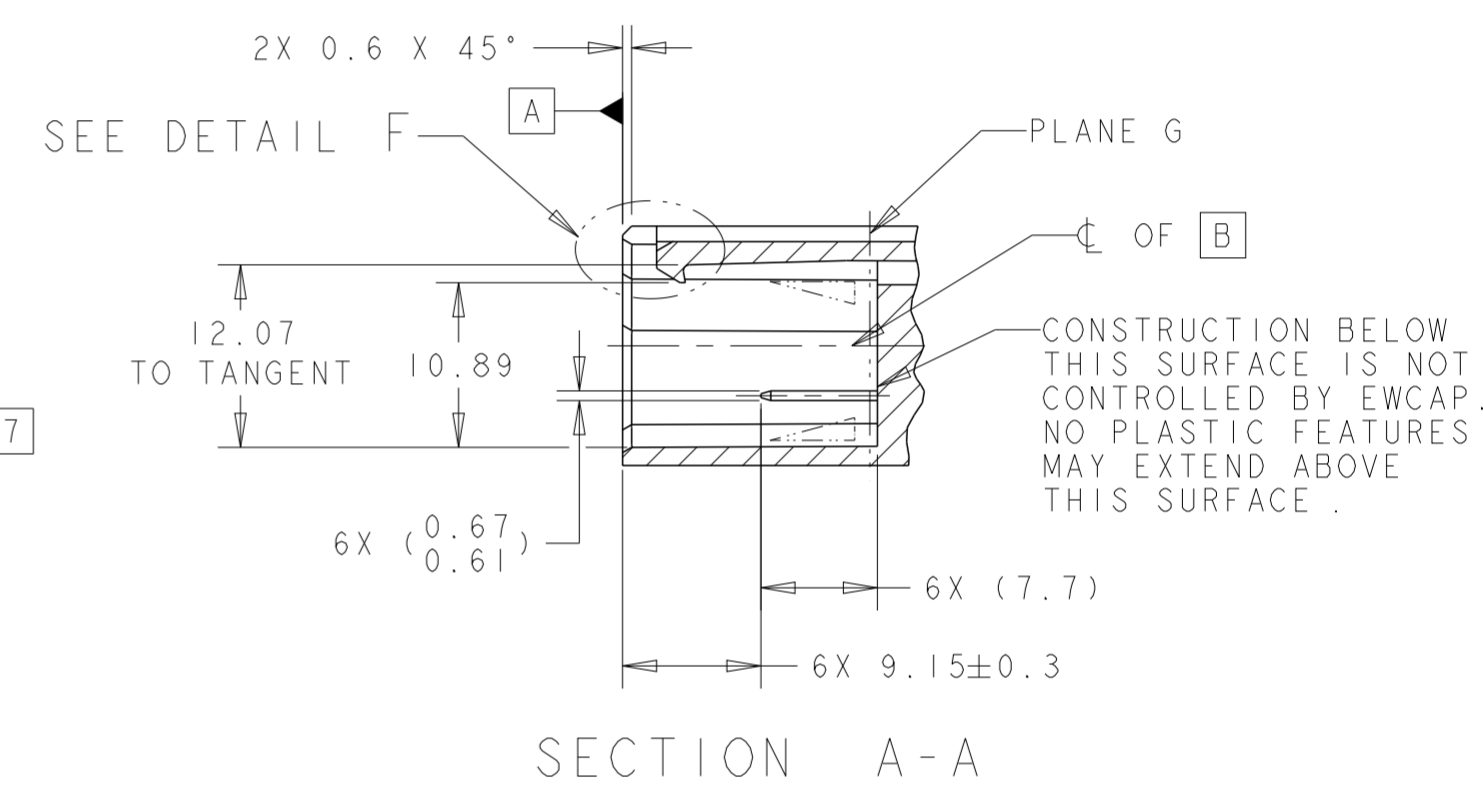
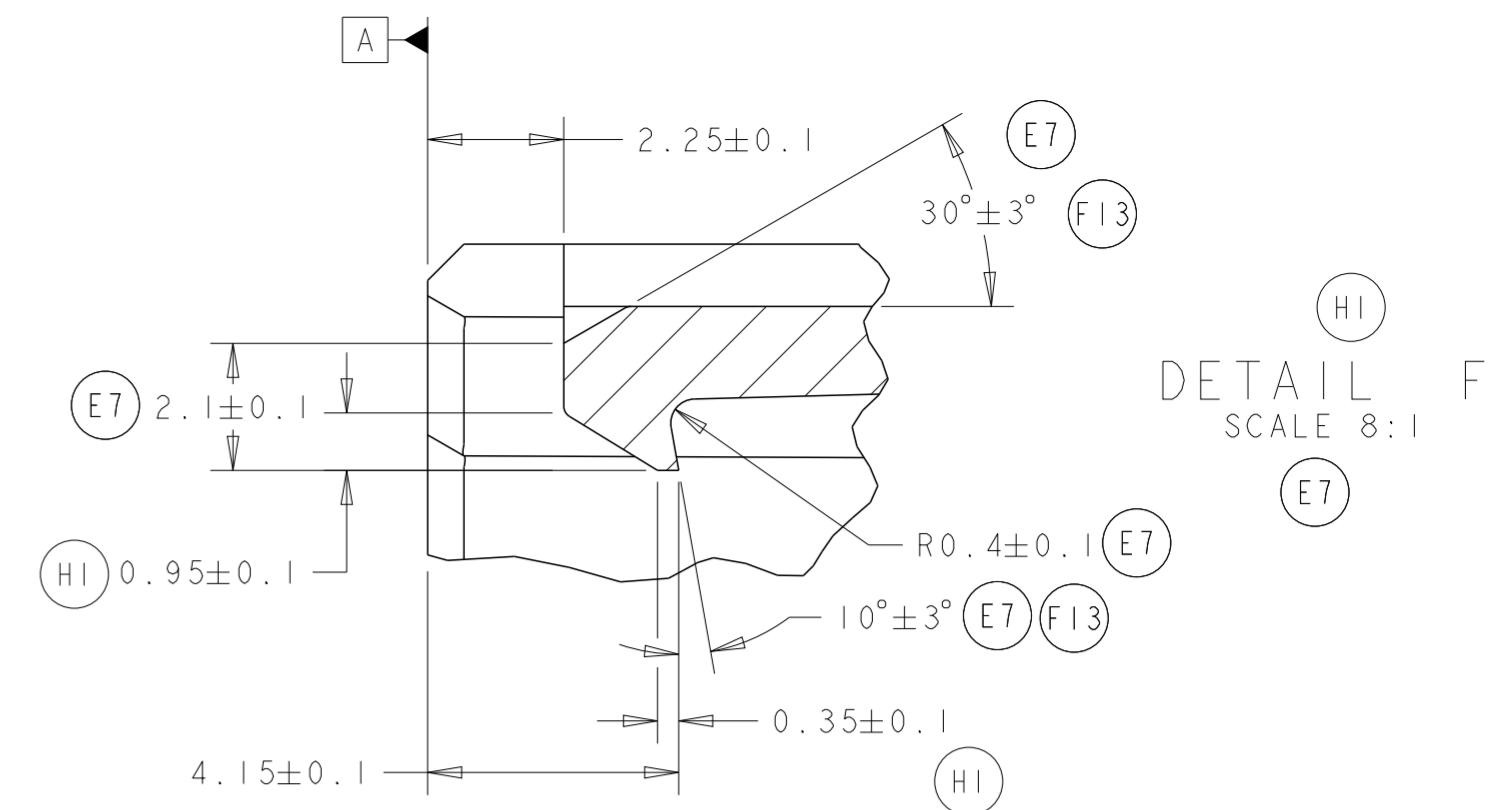
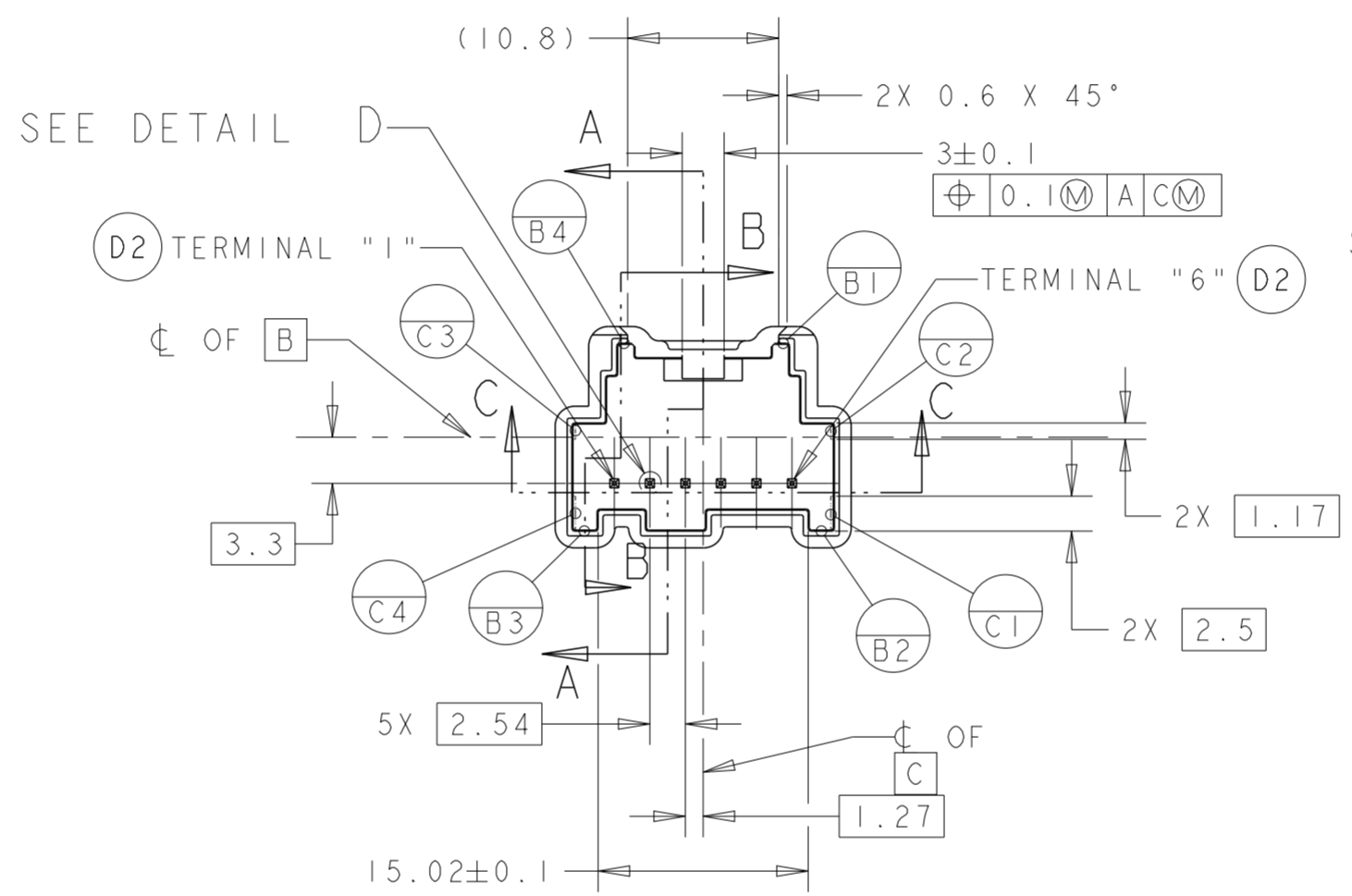
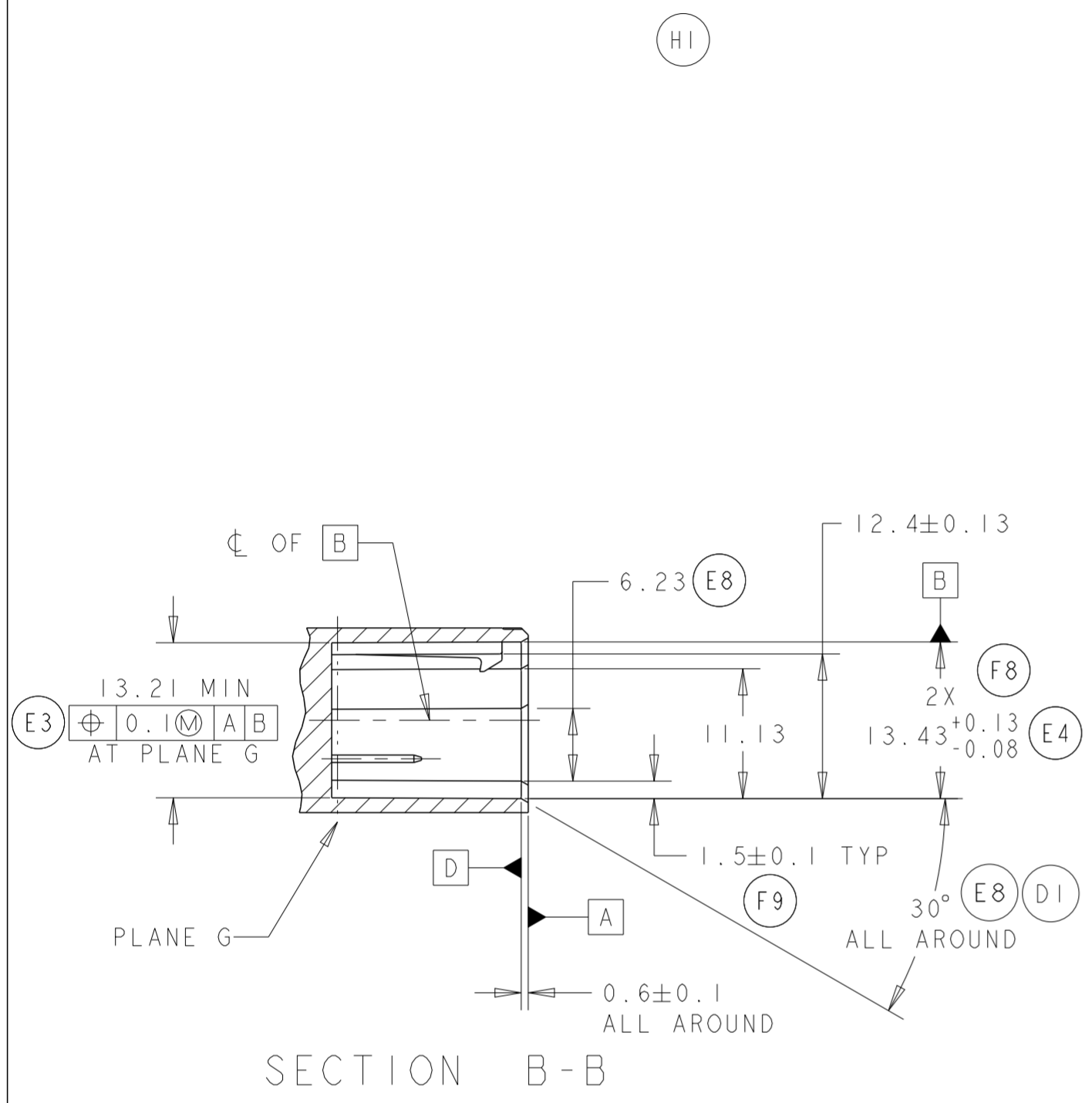

TOLERANCES (UNLESS OTHERWISE SPECIFIED)		THIRD ANGLE PROJECTION	
DIMENSIONS ARE IN MILLIMETERS			
ANGLES ± 2°			
X.X ± 0.25		X.XX ± 0.13	
USCAR-EWCAP			
SCALE 2:1	DRAWN BY N. SOOCH	CHECKED BY B. HULPIAU	DATE 05-17-01
TITLE 1 X 6 UNSEALED INTERFACE 0.64mm CONNECTORS			
SHEET 2 OF 2	DRAWING NUMBER 064-U-006-1-Z02	SIZE A2	DO NOT SCALE DRAWING COMPUTER AIDED DRAWING
			REVISION LEVEL H

