

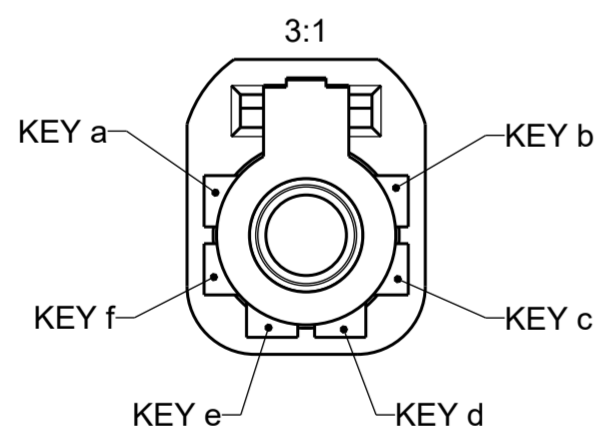

**CODING**

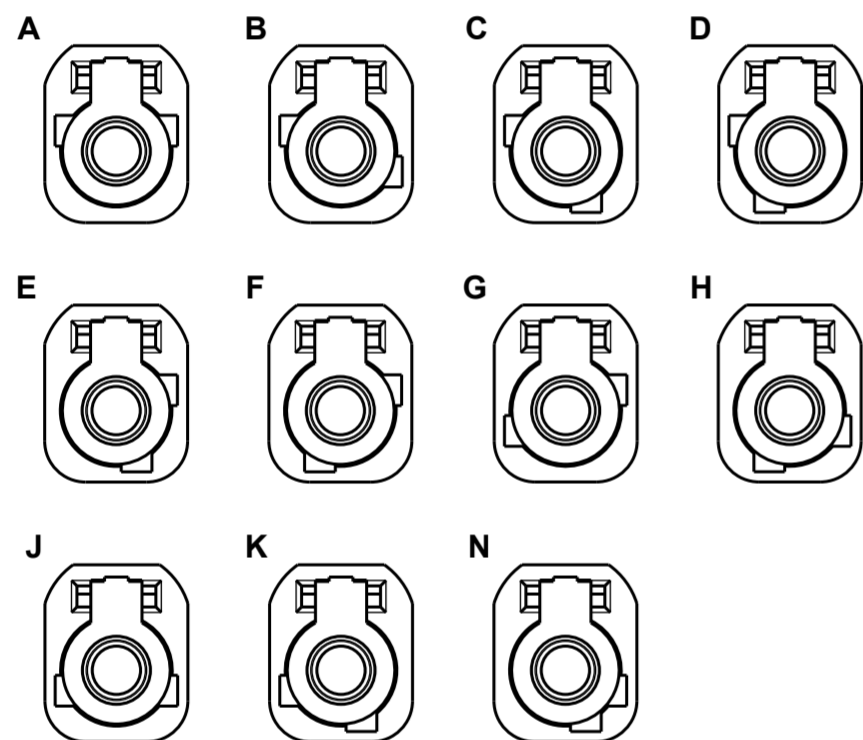

CODE	KEY	COLOR	SIMILAR RAL-NO
N	c-d	PASTEL GREEN	6019
K	d-f	CURRY	1027
J	c-f	BEIGE	1001
H	c-e	LIGHT PINK	3015
G	b-f	PLATINUM GREY	7036
F	b-e	NUT BROWN	8011
E	b-d	MAY GREEN	6017
D	a-e	CLARET VIOLET	4004
C	a-d	LIGHT BLUE	5012
B	a-c	PURE WHITE	9010
A	a-b	JET BLACK	9005

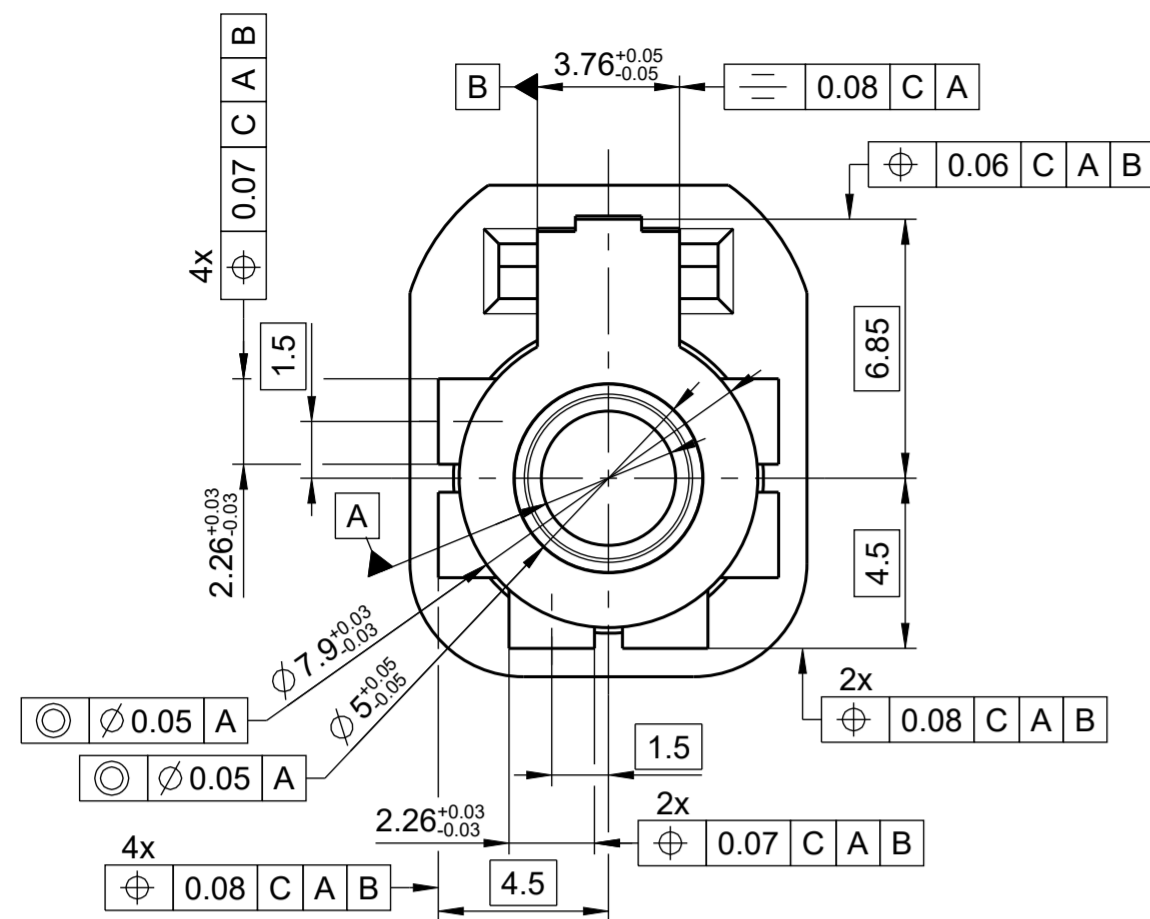
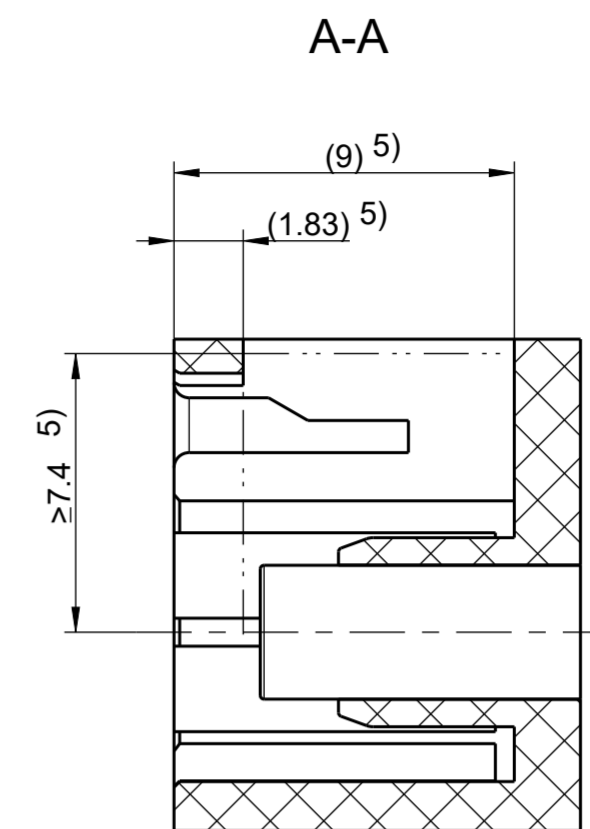
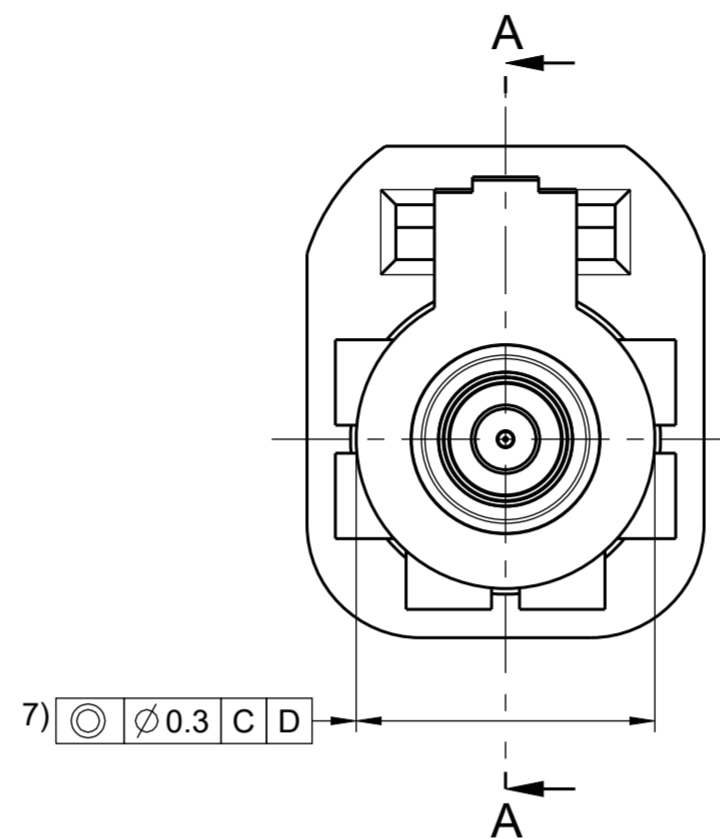

**Explanation of the Datum plane**

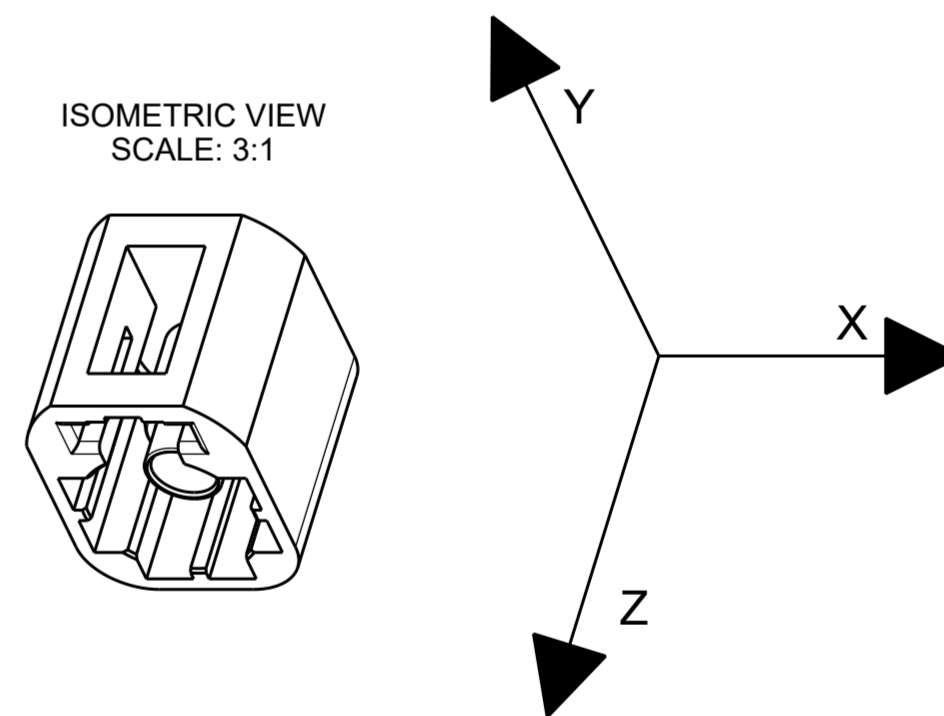

- A -> Orientation of the housing in the Z-direction on the XY plane, position of the outer contact
- B -> Limitation of the rotation about the Z-axis
- C -> Front surface
- D -> Outer contact is reference for inner contact

**REQUIRED SPACE FOR ACTUATION**

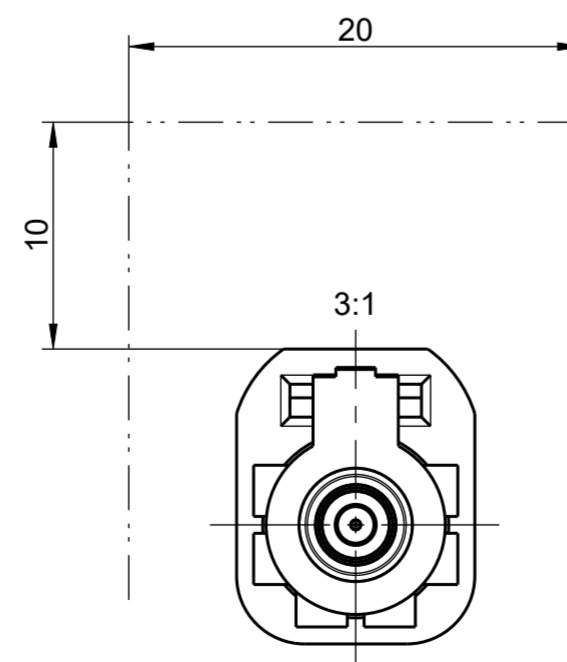

TOLERANCES (UNLESS OTHERWISE SPECIFIED)		THIRD ANGLE PROJECTION	
DIMENSIONS ARE IN MILLIMETERS			
SIZE ISO 14405 / TOLERANCING ISO 8015			
SCALE	DRAWN BY	CHECKED BY	DATE
5:1	R. SADIC	M. SINGHAMMER	01.02.2024
TITLE			
ISO 8092-7 Waterproof Type A			
SHEET	DRAWING NUMBER	SIZE	REVISION LEVEL
2 of 2		A2	COMPUTER AIDED DRAWING A