

ISOMETRIC VIEW
SCALE 1:1

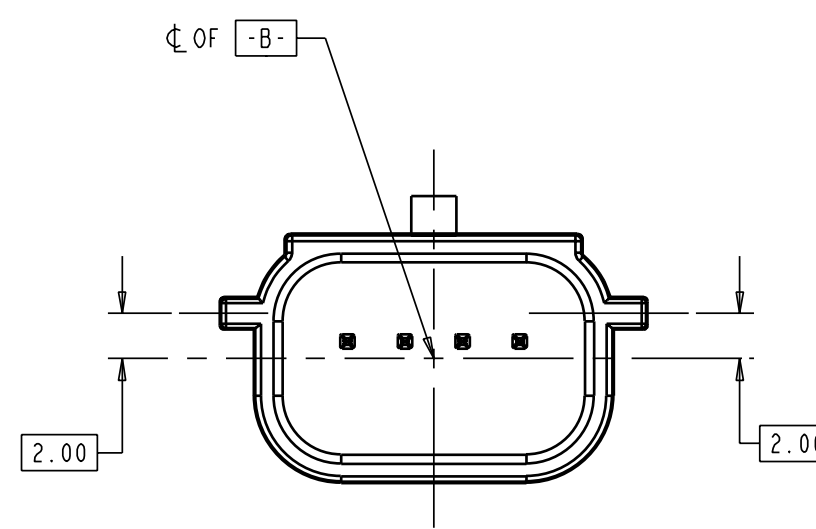

064-S-004-1-A02
(OPTION A)

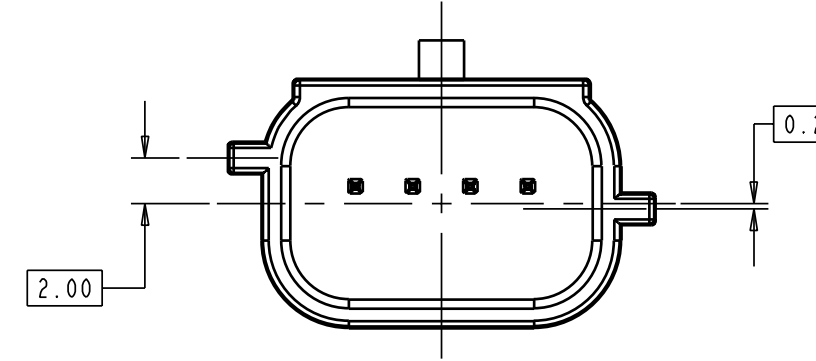

064-S-004-1-B02
(OPTION B)

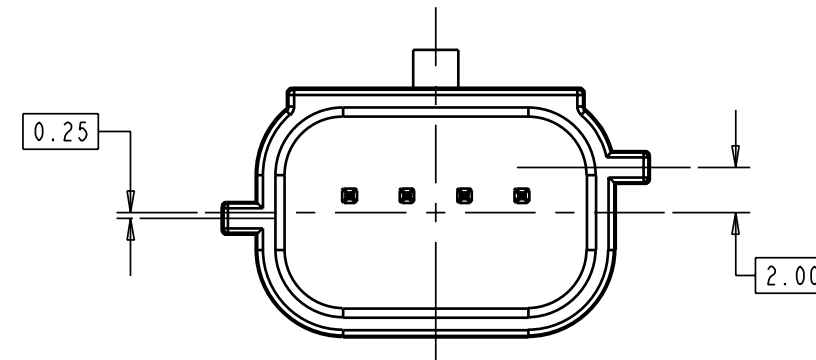

064-S-004-1-C02
(OPTION C)

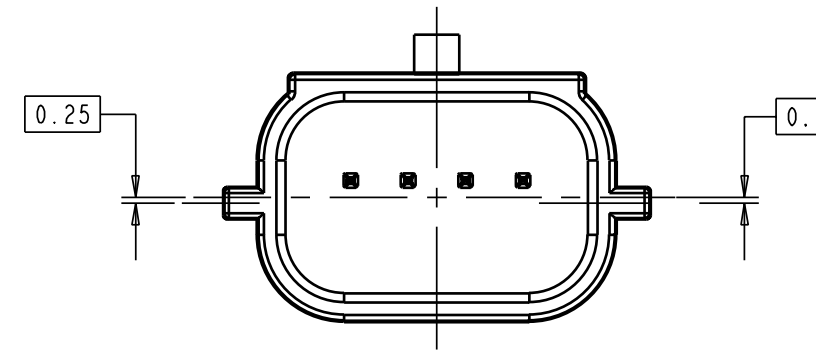

064-S-004-1-D02
(OPTION D)

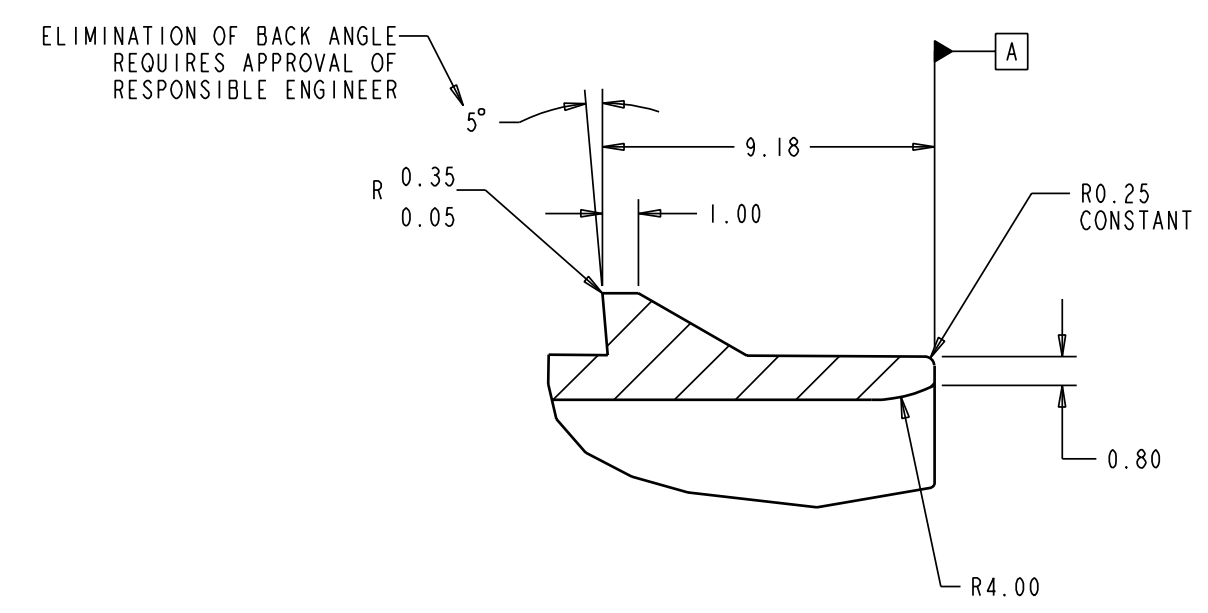

DETAIL A
SCALE 8:1

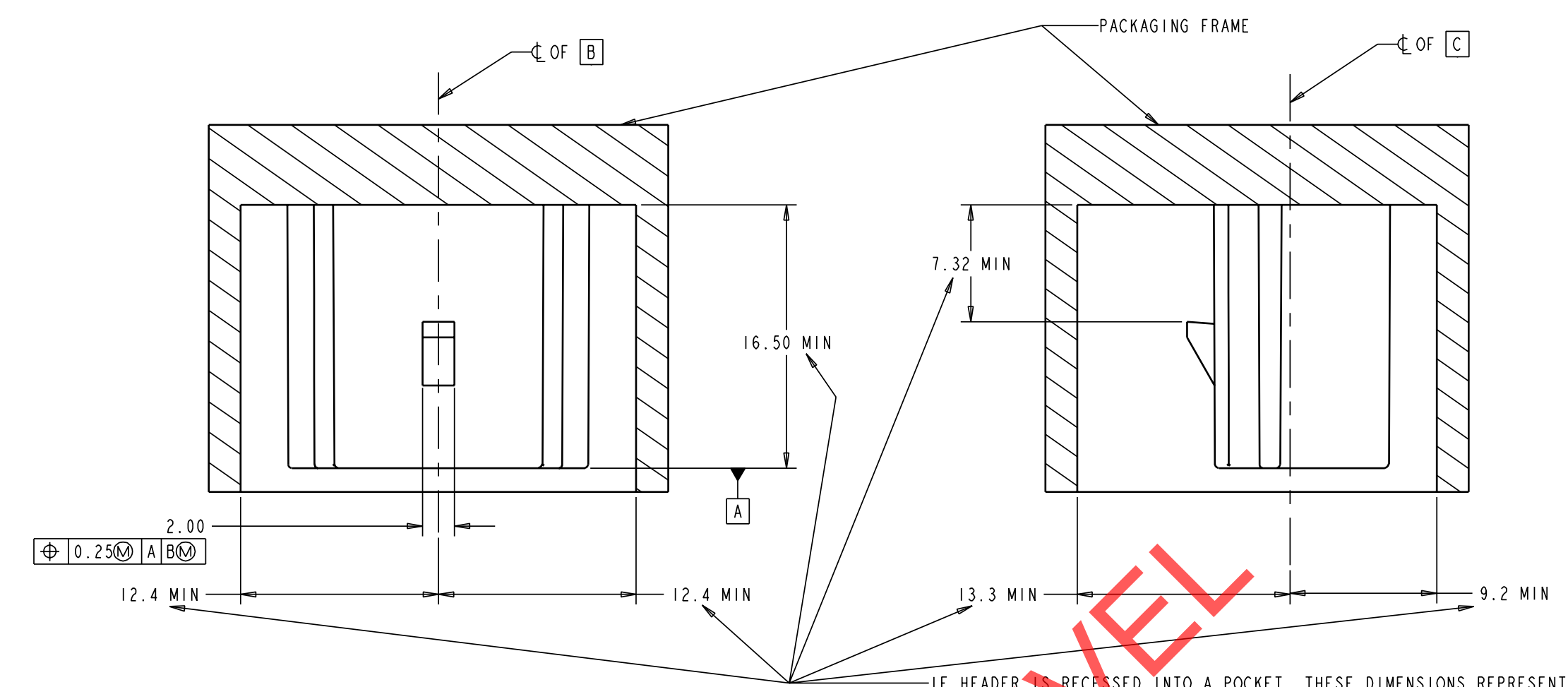

IF HEADER IS RECESSED INTO A POCKET, THESE DIMENSIONS REPRESENT THE CLEARANCE REQUIRED FOR THE MATING CONNECTOR SHROUD

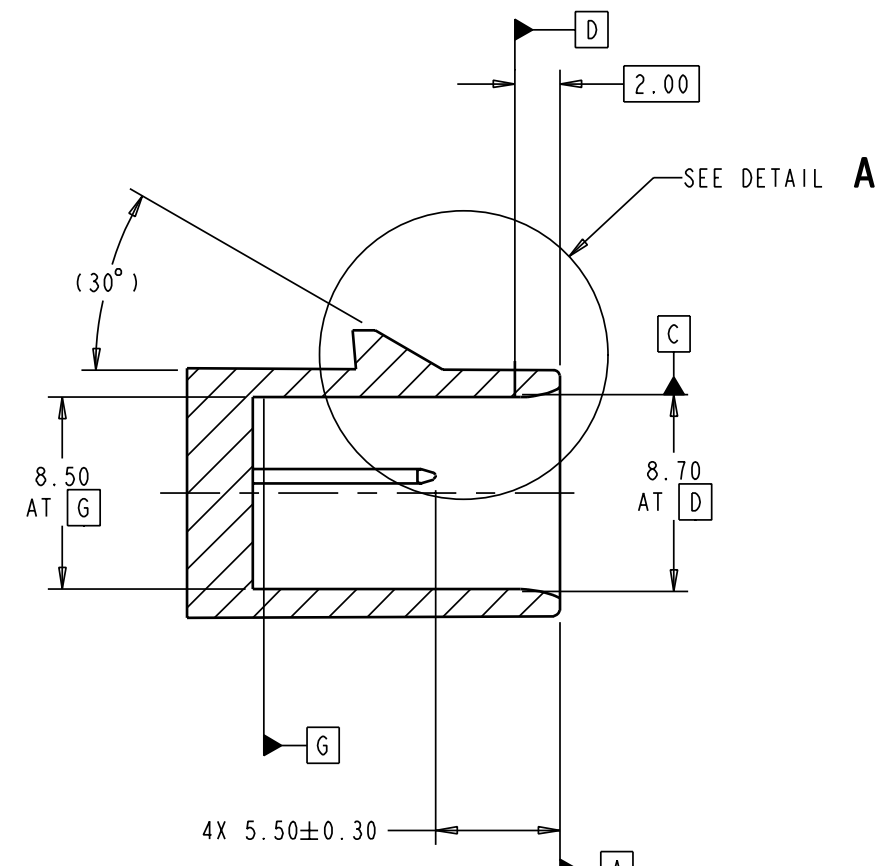

SECTION D-D

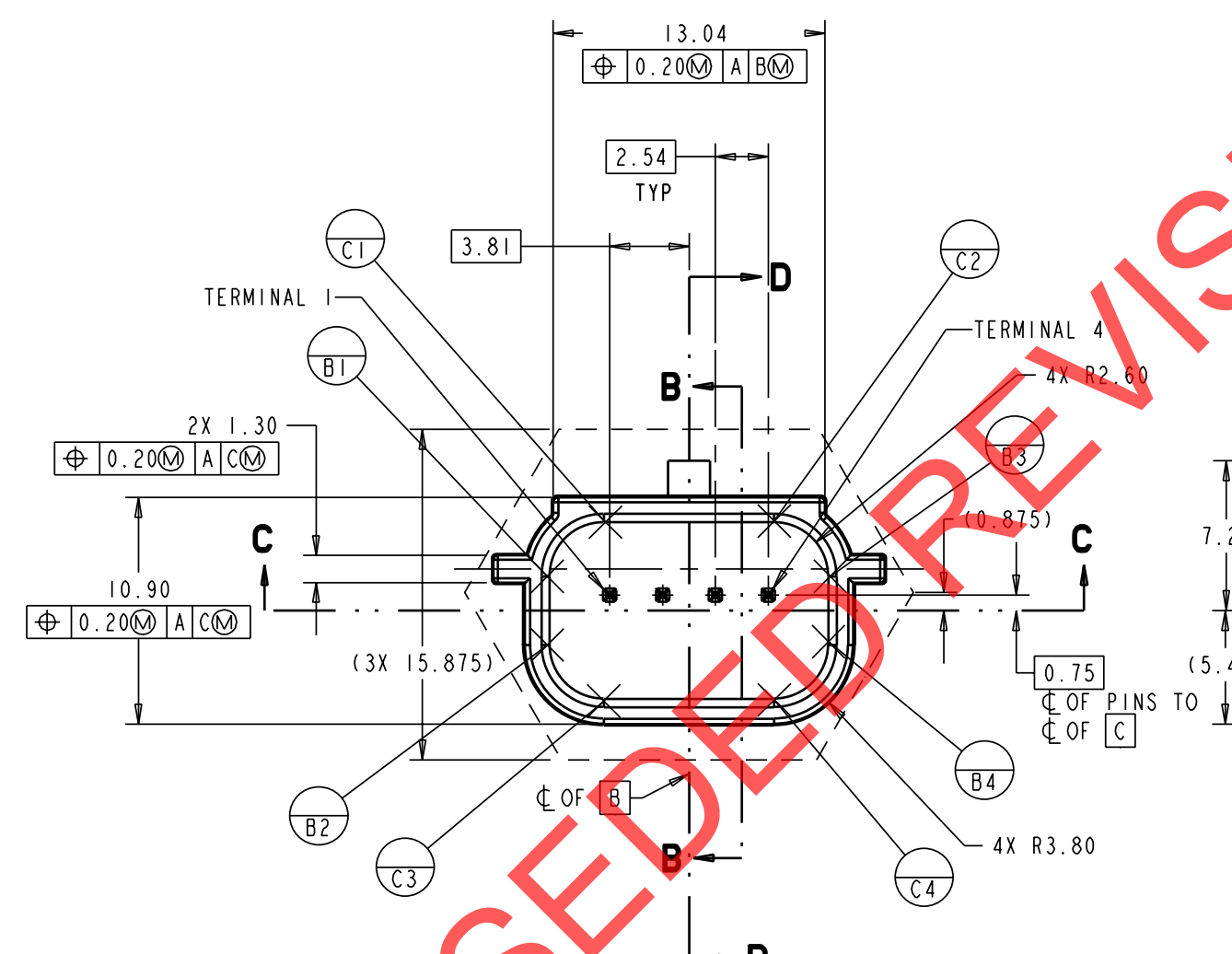

SUPERSEDED REVISION LEVEL

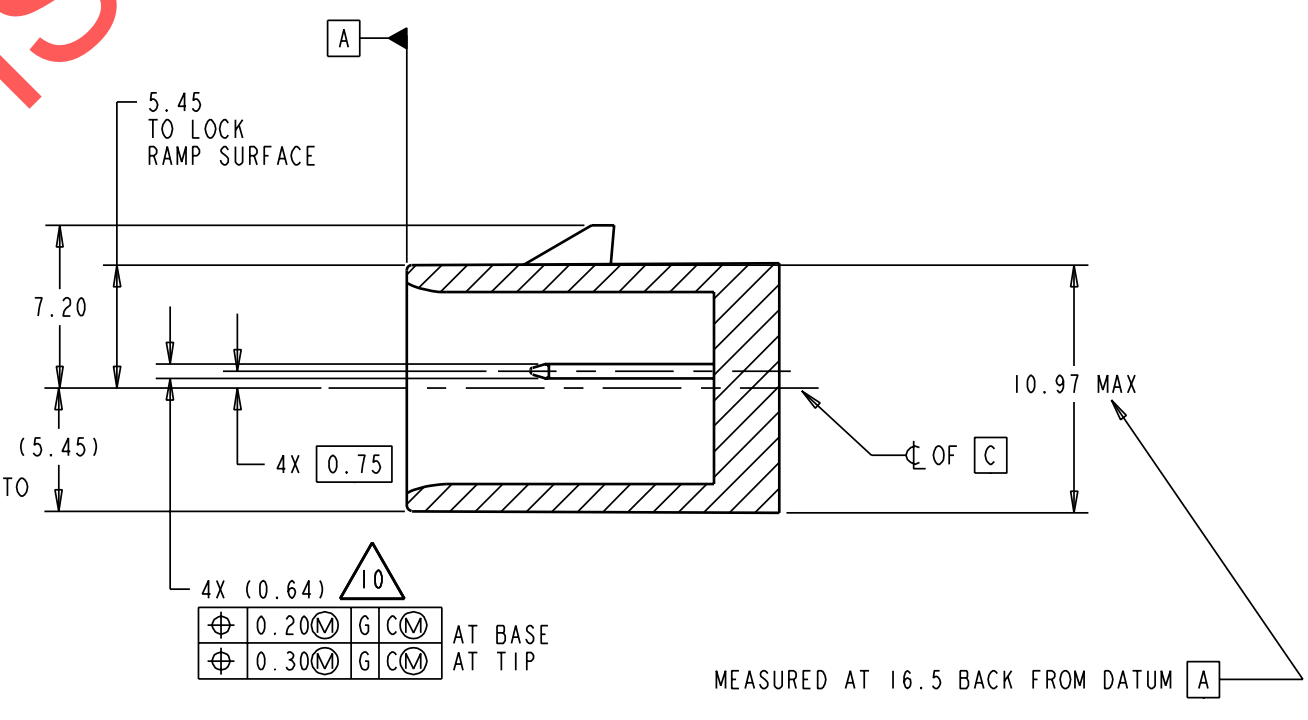

SECTION B-B

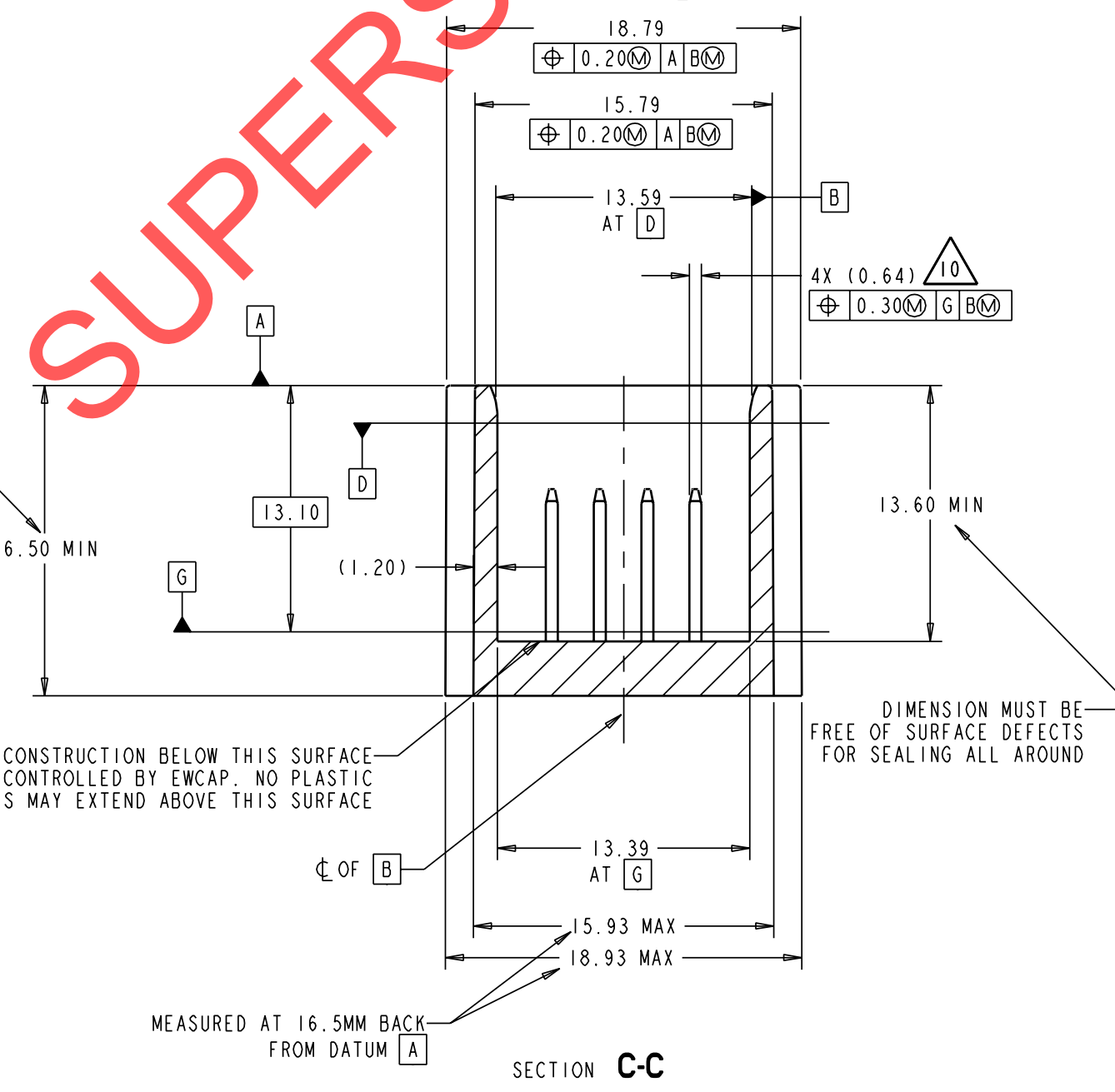

SECTION C-C

MINIMUM CLEARANCE REQUIRED ON OUTSIDE SURFACE OF HEADER FOR MATING CONNECTOR SHROUD

CONSTRUCTION BELOW THIS SURFACE IS NOT CONTROLLED BY EWCAP. NO PLASTIC FEATURES MAY EXTEND ABOVE THIS SURFACE

DIMENSION MUST BE FREE OF SURFACE DEFECTS FOR SEALING ALL AROUND

MEASURED AT 16.5MM BACK FROM DATUM A

NOTES: UNLESS OTHERWISE SPECIFIED

1. ALL DIMENSIONS SHOWN IN MILLIMETERS.
2. DIMENSIONING AND TOLERANCING PER ASME Y14.5M-1994.
3. RADII ON ALL CORNERS SHOWN SHARP OR ALL UNSPECIFIED RADII 0.25 EXCEPT AS NOTED.
4. REFER TO "SAE/USCAR-12 CONNECTOR DESIGN GUIDELINES FOR ADDITIONAL INFORMATION."
5. A FULL SHROUD ON THE MATING CONNECTOR IS REQUIRED TO INSURE THAT THE CONNECTOR-HEADER POLARIZATION FEATURES (OPTIONS A THROUGH D) WILL FUNCTION. THE FULL SHROUD ALSO PREVENTS SCOOP DAMAGE TO THE HEADER PINS. REFER TO "SAE/USCAR-12 CONNECTOR DESIGN GUIDELINES" FOR ADDITIONAL INFORMATION.
6. RECOMMENDED COLORS FOR POLARIZATION - DEVIATION REQUIRES APPROVAL OF AUTHORIZED PERSON.
7. 0.25 DEGREE DRAFT ON INSIDE WALLS STARTING AT DATUM G.
8. SECTION LINES ARE COMMON TO ALL OPTIONS.
9. DIMENSIONS IN () ARE FOR REFERENCE.
10. FOR PIN GEOMETRIC AND PLATING REQUIREMENTS, REFER TO EWCAP DWG. NO. EWCAP-001, DETAIL 064-T001.

69	B	ADDED 18.79 IN SECTION C-C	03-22-07	TS	SV
		ADDED 18.93 IN SECTION C-C			
	A	INITIAL RELEASE	09-26-03	DG	RC
CHANGE SERIAL NUMBER	LET	REVISION RECORD	DATE	DWN	CHK

TOLERANCES (UNLESS OTHERWISE SPECIFIED)			
DIMENSIONS ARE IN MILLIMETERS			
ANGLES ±3°			
.X ±0.2		.XX ±0.10	

SCALE	8 - 1	DRAWN BY	A. BUTCHER	CHECKED BY	D. GRIFFITHS	DATE	09-26-03
TITLE	DIRECT CONNECT INTERFACE						
	4 WAY (1 X 4) 0.64 mm SEALED MALE						
SHEET	DRAWING NUMBER	SIZE	DO NOT SCALE DRAWING	REVISION LEVEL			
1 of 1	064-S-004-1-Z02	E	COMPUTER AIDED DRAWING	B			

064-S-004-1-D02	D	GREEN
064-S-004-1-C02	C	BROWN
064-S-004-1-B02	B	GRAY
064-S-004-1-A02	A	BLACK
EWCAP P/N	OPTION	MATING CONNECTOR COLOR

